



# 工业缝纫机伺服控制器

## Industrial Sewing Machine Servo controller

---

# SU11G-G

使用说明书

User manual

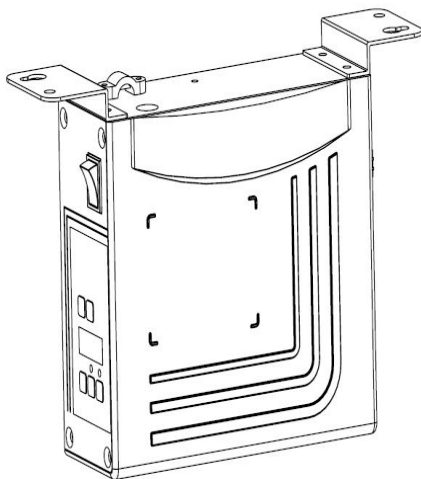

---

网址 / WEBSITE : [http:// www.ritech-sh.com](http://www.ritech-sh.com)

售后服务邮箱 / After-sales EMAIL : [service@ritech-sh.com](mailto:service@ritech-sh.com)

售后服务电话 / After-sales Service Telephone: 15921074315

# 目 录

前言 .....	1
1. 产品安装 .....	2
1.1. 产品规格 .....	2
1.2. 连线与接地 .....	2
1.3. 下挂电机的安装 .....	2
1.4. 直驱控制器的安装 .....	3
2. 控制器接口定义 .....	3
3. 操作面板概述 .....	4
3.1. 操作面板外观主界面 .....	4
3.2. 操作面板按键说明表 .....	5
3.3. 数码管界面简介 .....	5
4. 操作面板使用说明 .....	6
4.1. 快捷设置 .....	6
4.2. 技术员参数修改 .....	6
4.3. 研发参数修改 .....	7
4.4. 监控参数 .....	7
4.5. 错误回放 .....	8
4.6. 自动测试 .....	9
4.7. 传动比和初始角测试 .....	9
4.8. 操作注意事项 .....	9
附表 1 技术员参数表 .....	9
附表 2 监控参数表（只显示最高三位） .....	13
附表 3 故障代码表 .....	14

## 前言



注意

使用前请详细阅读本用户手册及所搭配的设备说明书，配合正确使用，并须由接受过专业培训的人员来安装或操作。

本产品仅适用于指定范围的设备，请勿移做其他用途。

使用中存有任何疑问或对我们的产品及服务有任何意见或建议，请随时与我们联系

## 安全事项

- 在使用本产品之前，请先阅读《产品说明书》及所搭配的缝纫机机械说明书。
- 本产品必须由接受过专业培训的人员来安装或操作。
- 请尽量远离电弧焊接设备，以免产生的电磁波干扰电控而发生误动作。
- 请不要在室温  $45^{\circ}$  以上或者  $0^{\circ}$  以下的场所使用。
- 请不要在湿度 30% 以下或者 95% 以上或者有露水和酸雾的场所使用。
- 安装控制箱及其他部件时，请先关闭电源并拔掉电源插头。
- 为防止干扰或漏电事故，请做好接地工程，电源线的接地线必须牢固的方式与大地有效连接。
- 所有维修用的零部件，须由本公司提供或认可，方可使用。
- 在进行任何保养维修动作前，必须关闭电源并拔掉电源插头。控制箱里有高压危险，必须关闭电源五分钟后方可打开控制箱。
- 本手册中标有  $\triangle$  符号之处为安全注意点，必须注意并严格遵守，以免造成不必要的损害。

# 1. 产品安装

## 1.1. 产品规格

产品型号	SU11G-G	输出电压	176VAC—264VAC
电源频率	50Hz/60Hz	最大输出功率	850W

## 1.2. 连线与接地

必须要做好系统的接地工程，请合格的电气工程人员予以施工。产品通电及投入使用前，必须确保电源插座 AC 输入端已安全可靠的接地。系统的接地线为黄绿线，该地线请务必可靠连接至电网安全保护接地上，以保证安全使用，并可防止出现异常情况。

 <b>注意</b>	<p>所有电源线、信号线、接地线等接线时不要被其它物体压到或过度扭曲，以确保使用安全！</p>
--	---

当电源系统配置为三相四线式 / 三相五线式 380V 时，欲使用单相 220V 供应本电机的接线方式。

 <b>注意</b>	<p>如果此配置系统没有【中性（点）线】时，本伺服电机不适合在此场所使用。</p>
--	---

## 1.3. 下挂电机的安装

**第一步：** 安装吊装螺栓。若缝纫机台板上无预留定位孔时则需按图 1-1 所示尺寸钻孔，置入定位吊装螺栓。



图 1-1 螺栓钻孔尺寸图

**第二步：** 安装电机（见图 1-2）。将电机吊上吊装螺栓后紧固。

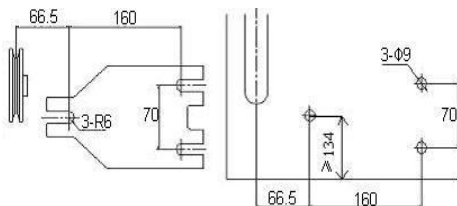

图 1-2 电机安装示意图

### 1.4. 直驱控制器的安装



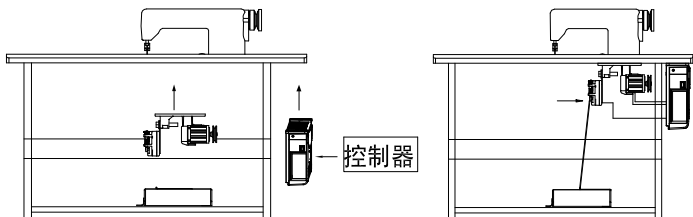

图 1-3 控制器安装示意图

## 2. 控制器接口定义

控制箱与电机同步传感器组件、操作面板和电源线等的连接如图 2-1 所示，将各个连线的插头插入控制箱上对应的插座即可。装好后，检查一下插头是否插牢。

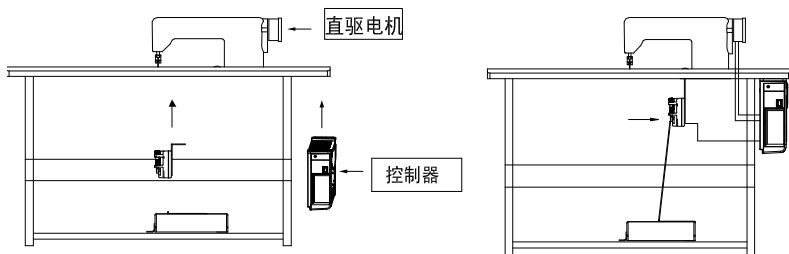
 注意	使用正常的力量插不进去时，请检查插头与插座是否匹配，插入方向或针的方向是否正确。
---	--



图 2-1 控制器对外接口示意图

### 3. 操作面板概述

#### 3.1. 操作面板外观主界面

SU11G-G 控制器操作面板（如图 3-1 所示）由数码显示区域及上下双排按键组成。在整个操作面板正面的中间位置，为数码显示区域。主要由 3 个数码管构成，用于显示功能设置参数。在操作面板数码显示区域上方，有两个按键，分别为“功能键”、“保存键”。在数码显示区下方，有 3 个按键，其中右边两个按键的上方各有一个有 LED 显示灯，来显示按键对应的功能状态是否开启。

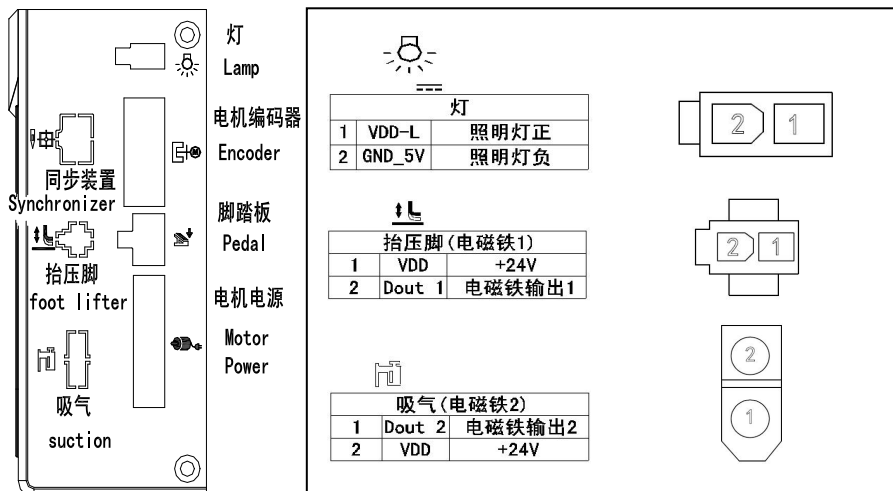





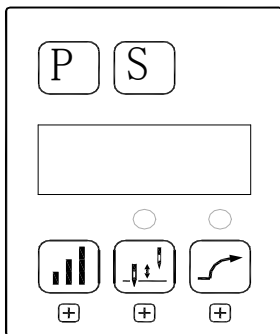

图 3-1 控制器面板布局

### 3.2. 操作面板按键说明表

按键图标	按键名称	功能描述
	功能键	与其它按键组成组合按键；密码输入界面确认，其他界面返回功能。在参数修改界面按动一次起到返回到初始界面作用，不保存当前的参数。
	保存键	认功能（除密码输入界面）在修改参数界面下按动则系统保存参数的修改。
	百位键	可调速。在参数修改时，此按键用于修改最高位的参数。另外该按键可与P键组合进入参数修改界面。
	停针键	用于设定上下停针位置；同时该按键兼做用于修改中间数码管的数据数值，每次有效按动一次增加一位数值。
	软启动键	用于选择软启动功能；同时该按键兼做修改最后一位数码管的数据数值，每次有效按动一次增加一位数值。

### 3.3. 数码管界面简介

数码管的显示界面分三种状态：空闲状态，索引状态和数据显示状态。

#### 3.3.1. 空闲状态：刚上电时，界面默认处于空闲状态。



图 3-2 空闲状态时数码管的显示

#### 3.3.2. 索引状态：分三种情况



图 3-3 参数索引状态



图 3-4 监控索引状态



图 3-5 错误回放弃索引

### 3.3.3. 数据显示状态:

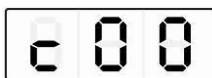
分别显示不同索引下的对应的数据—技术员参数、监控参数和错误代码。

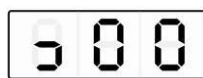

图 3-6 数码管显示区域的数据显示状态

## 4. 操作面板使用说明

### 4.1. 快捷设置

在空闲状态界面下，可以快速进行软启动和停针位设置。

#### 4.1.1. 软启动设置

操作界面处于空闲状态（如图 3-2）时，按 （软启动键）后，可以在软启动打

开和关闭之间切换。上方 LED 灯会亮表明软启动开启（），再按一下软启动

关闭，按键上方 LED 灯会熄灭（）。

#### 4.1.2. 停针位设置

操作界面处于空闲状态（如图 3-2）时，按 （停针键），进行上/下停针设置。

停针位键上方 LED 灯亮（）表示下停针；再按一下上方的 LED 灯会自动熄灭

（）表示上停针。

### 4.2. 技术员参数修改

在实际应用中，可以根据需要使用，调整或重设各功能模式的相应技术参数，使系统工作在最好的工况下，进入参数设定的方法如下：



第一步：在空闲界面下，先按下 （功能键）不放，再按下 （百位键），两键同时按下后，数码管会显示如图 4-1，要求键入密码。默认密码 000。



图 4-1 密码界面







第二步：按动  (百位键)、 (停针键)、 (软启动键) 修改数码管显示数值至正确的密码，然后按下  (功能键) 确认。如果密码正确，即进入参数修改索引，显示如图 4-2。



图 4-2 技术员索引

第三步：在参数索引下，按动  (停针键)、 (软启动键) 修改数码管显示数值至需要的技术员参数索引号。技术员参数数值定义详见附表 1《技术员参数表》。索引号确定后，按  (保存键) 进入参数界面，如图 4-3。









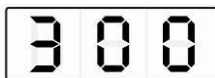

图 4-3 技术员参数

第四步：按动  (百位键)、 (停针键)、 (软启动键) 修改数码管显示数值至需要的参数值。

第五步：参数修改完毕后，按  (保存键) 确认参数修改并返回到索引界面。如不想保存修改按  (功能键)，返回至空闲界面。

任何时候都可以按  (功能键) 返回至空闲界面。

### 4.3. 研发参数修改

先按下  (功能键) 不放，再打开电源开关，即可进入研发参数；其它操作方法同技术员参数操作方法。



### 4.4. 监控参数

第一步：在空闲界面下，先按下  (功能键) 不放，再按下  (停针键)，两

键同时按下后，数码管会显示如图 4-4，监控索引界面。



图 4-4 监控索引

第二步：在参数索引下，按动 （停针键）、（软启动键）修改数码管显示数值至需要的监控索引号。监控索引号定义详见附表 2《监控索引参数表》。索引



号确定后，按 （保存键）进入监控参数界面，如图 4-5。



图 4-5 监控参数

第三步：在监控参数数据界面按除 （功能键）任意一键，返回到监控参数索引

界面。按 （功能键）返回至空闲态界面。

第四步：重复第二步查看其他监控参数或第三步退出监控状态。

#### 4.5. 错误回放

错误回放功能按故障发生的先后顺序，依次保存着控制器最近发生的 8 次故障代码。即 0 号索引下保存的是最近发生故障代码，1 号索引保存的是 0 号索引错误前一次发生的故障。故障代号与故障对应关系参看附表 3《故障代码表》。





第一步：在空闲界面下，先按下 （功能键）不放，再按下 （软启动键），两键同时按下后，数码管会显示如图 4-6。



图 4-6 错误回放索引

第二步：在错误回放索引下，按动 （停针键）、（软启动键）修改数码管

显示数值至需要的错误回放索引号（0-7）。错误索引号显示正确后，按 （保存键）进入错误记录界面，查看该索引号所记录的故障代码。如图 4-7。



图 4-7 故障代码显示

第三步：在故障代码显示界面按除 **P** (功能键) 任意一键，返回到错误回放索引界面，而按 **P** (功能键) 则直接返回至空闲态界面。

#### 4.6. 自动测试

在空闲状态界面，按下 **P** (功能键) 和 **S** (保存键) 组合键，再踩下踏板控制器进入自动测试状态。控制器会根据设定的测试模式和测试时间运行，直到测试结束。再次按下 **P** (功能键) 和 **S** (保存键) 的组合键，运行停止后退出自动测试。

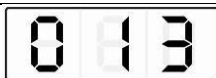
#### 4.7. 传动比和初始角测试

在空闲状态界面，按下 **P** (功能键) 和 **||** (百位键) 组合键，进入技术员参数：

初始角测试：P18 参数调整为 2 (测试初始角)，踩下踏板开始测试，测试完后将参数调回 0 即可 (正常运行模式)。

传动比测试：P18 参数调整为 3 (测试传动比)，踩下踏板开始测试，测试完后将参数调回 0 (正常运行模式)。

#### 4.8. 操作注意事项

为了使系统运行在最佳状态，客户第一次使用时建议测试一遍初始角度和传动比。研发参数尽量不要随意修改，修改不当会影响正常使用。

附表 1 技术员参数表

分类	索引号	默认设置	参数范围	注释
速度	P00	20	10~80	缝纫最低速度 (数码显示值*10)
	P01	350	20~700	缝纫最高速 (全局最高限速) (数码显示值*10)
	P02	2	1~9	软启动起缝针数

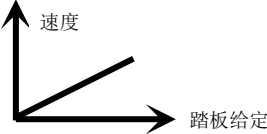
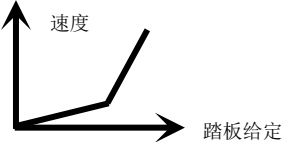
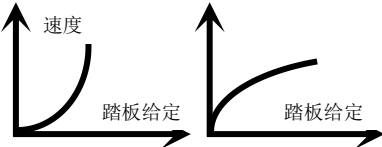
	<p><b>P03</b></p>	<p><b>20</b></p>	<p>10~80</p>	<p>软启动最大速度(数码显示值*10)</p>
	<p><b>P04</b></p>	<p><b>13</b></p>	<p>1~20</p>	<p>加速灵敏度(对于直驱机头可设置为较大的值;对于皮带传动不要设置太大,否则振动、噪声较大。此参数不影响电机出力)</p>
	<p><b>P05</b></p>	<p><b>13</b></p>	<p>1~80</p>	<p>减速灵敏度(对于直驱机头可设置为较大的值;对于皮带传动不要设置太大,否则振动、噪声较大。此参数不影响电机出力)</p>
<p>踏板</p>	<p><b>P08</b></p>	<p><b>2</b></p>	<p>0 / 1 / 2 / 3</p>	<p>脚踏板曲线模式:                      0: 自动线性斜率(根据最高速自动计算)</p>  <p>1: 两段斜率</p>  <p>2: 幂次曲线</p>  <p>3: S 型曲线</p>

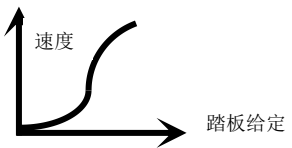
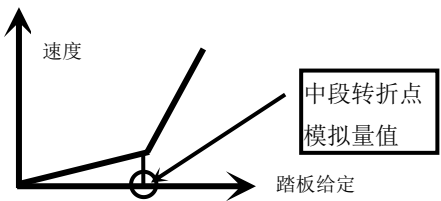
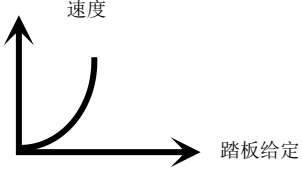
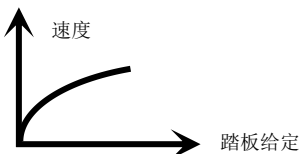
				 <p>速度</p> <p>踏板给定</p>
踏板	P09	300	20~400	<p>两段控速斜率辅助参数：中段转折点速度 RPM（两段斜率的转折点速度），在参数【8】设置为 1 时有效。</p>  <p>速度</p> <p>中段转折点速度</p> <p>踏板给定</p>
	P10	800	0~999	<p>两段控速斜率辅助参数： 中段转折点踏板模拟量值，当参数【8】设置为 1 时有效，参数设定值需在参数【15】到【16】的值之间。</p>  <p>速度</p> <p>中段转折点模拟量值</p> <p>踏板给定</p>
	P11	1	1 / 2	<p>幂次控速曲线辅助参数： 在参数【8】设置为 2 时有效。</p> <p>1：平方（先缓后快，低速操控性好）</p>  <p>速度</p> <p>踏板给定</p> <p>2：开方（先快后缓，响应速度快）；</p>  <p>速度</p> <p>踏板给定</p>

	<b>P12</b>	<b>190</b>	0~999	踏板后踏上提针位置 (设定值不得高于参数【13】)
	<b>P13</b>	<b>460</b>	0~999	踏板回中位置 (设定值介于参数【12】和【14】之间)
	<b>P14</b>	<b>480</b>	0~999	踏板前踩运行位置 (设定值介于参数【13】和【15】之间)
	<b>P15</b>	<b>680</b>	0~999	踏板低速运行位置 (上限) (设定值介于参数【14】和【16】之间)
	<b>P16</b>	<b>940</b>	0~999	踏板模拟量最大值 (设定值不得低于参数【15】)
习惯 设定 1	<b>P17</b>	<b>1</b>	0 / 1	上电自动找上针位功能设置: 0: 上电不找上针位 1: 上电寻找上针位
	<b>P18</b>	<b>0</b>	0 / 1 / 2 / 3	特殊运行模式: 0: 自由缝模式; 1: 简易缝模式; (无停针运行模式在同步传感器故障情况下使用); 2: 测电机初始角 (不再需要取下皮带); 3: 计算传动比模式 (需要有停针传感器, 且不能取下皮带)
	<b>P21</b>	<b>40</b>	10~80	上提针速度 (数码显示值*10)
	<b>P22</b>	<b>350</b>		自动测试速度
	<b>P25</b>	<b>0</b>	0 / 1	电机转向: 1: 反转; 0: 正转
机头 相关 参数	<b>P26</b>	<b>100</b>	10~500	电机/机头传动比: 0.001 (如果自动计算过传动比, 控制器内的该参数可能与 HMI 上的不同) (数码显示值*10)
	<b>P27</b>	<b>0</b>	0~359	上针位机械角度
	<b>P28</b>	<b>175</b>	0~359	下针位机械角度
启停 模式	<b>P31</b>	停针位	0: 上针位; 1: 下针位	
	<b>P32</b>	软启动模式	0: 关闭软启动; 1: 开启软启动	
自动 测试	<b>P33</b>	<b>0</b>	1	自动测试模式选择: 0: 定针数; 1: 定时间
	<b>P34</b>	<b>30</b>	0~999	自动测试总时间设定 (10 分钟)

	<b>P35</b>	<b>90</b>	1~999	运行时间 (0.1 秒) / 针数
	<b>P36</b>	<b>10</b>	1~999	停止时间 (0.1 秒)
参数 保存 恢复	<b>P37</b>	<b>0</b>	0~11	参数重载 (0: 平缝直驱; 3: 厚料; 6: 360 平缝直驱; 7: 360 平缝皮带; 8: 360 绷缝皮带; 10: 套式绷缝; 11: 罗拉车; 12: 双针直驱; 13: 皮带包缝; 14: 套式包缝)
	<b>P38</b>	0/1		参数转移: 0:数据写出                      1:读入数据;
	<b>P73</b>	<b>280</b>	0~999	抬压脚位置
	<b>P74</b>	<b>10</b>	0~999	踏板抬压脚确认时间 (10ms)
	<b>P75</b>	<b>10</b>	0~999	踏板放压脚延迟时间 (10ms)
	<b>P76</b>	<b>1</b>	0~999	电磁铁 1Chopping 开通时间
	<b>P77</b>	<b>1</b>	0~999	电磁铁 1Chopping 关断时间
	<b>P78</b>	<b>80</b>	0~600	电磁铁 1 超时保护时间(100ms)
	<b>P79</b>	<b>800</b>	0~999	电磁铁 1 全出力时间
	<b>P80</b>	<b>1</b>	0~3	电磁铁 1 功能: 0:关闭; 1: 抬压脚; 2: 吸气; 3: 24V 输出
	<b>P81</b>	<b>1</b>	0~999	电磁铁 2Chopping 开通时间
	<b>P82</b>	<b>1</b>	0~999	电磁铁 2Chopping 关断时间
	<b>P83</b>	<b>80</b>	0~600	电磁铁 2 超时保护时间(100ms)
	<b>P84</b>	<b>800</b>	0~999	电磁铁 2 全出力时间
		<b>P85</b>	<b>2</b>	0~3
	<b>P86</b>	<b>20</b>	20~300	补针速度
	<b>P87</b>	<b>150</b>	1~999	补半针延迟时间
	<b>P88</b>	<b>150</b>	1~999	补一针延迟时间
	<b>P89</b>	<b>0</b>	0~2	输入 1 功能: 0:关闭; 1: 安全开关; 2: 补针;
	<b>P90</b>	<b>0</b>	0~1	输入 1 有效电平

附表 2 监控参数表 (只显示最高三位)

索引号	注释	单位
0	母线电压	V
1	机械速度	10r/m
2	Q 轴电流	0.01A
3	初始角度	degree

4	机械角度	degree
5	脚踏板模拟采样值	--
6	传动比	0.001
7	版本号	

附表 3 故障代码表

故障代码	代码含义	解决措施
01	硬件过流	关闭系统电源，30 秒后重新接通电源，控制器若仍不能正常工作，请更换控制器并通知厂方。
02	软件过流	
03	系统欠压	断开控制器电源，检查输入电源电压是否偏低（低于 190V）。若电源电压偏低，在电压恢复正常后重启仍不能正常工作，请更换控制器并通知厂方。
04	停机时过压	断开控制器电源，检查输入电源电压是否偏高（高于 245V）。若电源电压偏高，请在电压恢复正常后重新启动控制器。若电压恢复正常后，启动控制器仍不能正常工作，请更换控制器并通知厂方。
05	运行时过压	
07	电流检测回路故障	关闭系统电源，30 秒后重新接通电源观察是否能正常工作。不行的话重试几次，若该故障频繁出现，需请求技术支援。
08	电机堵转	断开控制器电源，检查电机电源输入插头是否脱落、松动、破损，是否有异物缠绕在机头上。排除后重启系统仍不能正常工作，请更换控制器并通知厂方。
09	制动回路故障	关闭系统电源，检查电源板上白色的制动电阻接头是否松动或脱落，将其插紧后重启系统。若仍不能正常工作，请更换控制器并通知厂方。
11	机头停针信号故障	检查机头同步信号装置与控制器的连线是否松动，将其恢复正常后重启系统。若仍不能正常工作，请更换控制器并通知厂方。
12	电机初始角度检测故障	请断电后再尝试 2~3 次，或取下皮带再尝试，若仍报故障请更换控制器并通知厂方。
13	电机 HALL 故障	关闭系统电源，检查电机传感器接头是否松动或脱落，将其恢复正常后重启系统。若仍不能正常工作，请更换控制器并通知厂方。
14	DSP 读写 EEPROM 故障	请断电后再尝试 1 次，若仍报故障，请更换控制器并通知厂方。
15	电机超速保护	关闭系统电源，30 秒后重新接通电源观察是否能正常工作。不行的话重试几次，若该故障频繁出现，请更换控制器并通知厂方。

16	电机反转	关闭系统电源， 30 秒后重启系统，若仍不能正常工作，请更换控制器并通知厂方。
18	电机过载	关闭系统电源， 30 秒后重启系统，若仍不能正常工作，请更换控制器并通知厂方。

## Table of Contents

<b>1. INSTALLATION INSTRUCTIONS .....</b>	<b>2</b>
<b>1.1. SPECIFICATION .....</b>	<b>2</b>
<b>1.2. WIRING AND GROUNDING .....</b>	<b>2</b>
<b>1.3. MOTOR INSTALLATION .....</b>	<b>2</b>
<b>1.4. CONTROLLER INSTALLATION .....</b>	<b>3</b>
<b>2. DEFINITION OF CONTROLLER INTERFACE .....</b>	<b>3</b>
<b>3. OPERATION PANEL (HMI) INSTRUCTION .....</b>	<b>4</b>
<b>3.1. PANEL INSTRUCTION .....</b>	<b>4</b>
<b>3.2. FUNCTION OF KEY .....</b>	<b>4</b>
<b>3.3. DIGITAL INTERFACE INSTRUCTION .....</b>	<b>5</b>
<b>4. USE INSTRUCTIONS FOR OPERATOR PANEL .....</b>	<b>5</b>
<b>4.1. SHORTCUT SET .....</b>	<b>5</b>
<b>4.2. TECHNICAL MODE .....</b>	<b>6</b>
<b>4.3. R&amp;D PARAMETER MODIFICATION .....</b>	<b>7</b>
<b>4.4. MONITOR MODE .....</b>	<b>7</b>
<b>4.5. ERROR PLAYBACK .....</b>	<b>8</b>
<b>4.6. AUTOMATIC TEST .....</b>	<b>9</b>
<b>4.7. TRANSMISSION RATIO AND THE INITIAL ANGLE TEST .....</b>	<b>9</b>
<b>4.8. OPERATION NOTE .....</b>	<b>10</b>
<b>TABLE 1: TECHNICIAN MODE PARAMETER : .....</b>	<b>10</b>
<b>TABLE 2: MONITOR MODE PARAMETER (SHOW ONLY THE HIGHEST OF 3 BIT) .....</b>	<b>15</b>
<b>TABLE 3: ERROR CODE .....</b>	<b>15</b>

## Preface



**CAUTION**

**Please read this manual carefully, also with related manual for the machinery before use the controller. For installing and operating the controller properly and safely, qualified personnel are required.**

This product is designed for specified sewing machines and must not be used for other purposes.

If you have any problem or any comment, please feel free to contact us.

### Safety Precautions

- Please read the user manual and the corresponding mechanical instructions of the sewing machine before using this product.
- This product must be installed or operated by the qualified personnel who are subject to the professional training.
- Please be far away from the electric arc welding equipment to prevent misoperation due to the interference to the electrical control by the electromagnetic wave generated.
- It is prohibited to operate the product in places where the room temperature is 45° and above or is 0° and below.
- It is prohibited to operate the product in places where the humidity is 30% and below or is 95% and below, or there is dew or acid mist.
- Before installing the control box and other parts, please turn off the power and unplug the power plug.
- In order to prevent interference or electric leakage accident, grounding engineering is required. The grounding line of the power cord must be effectively and firmly connected to the earth.
- All repaired parts must be provided or approved by our company before use.
- Please turn off the power and unplug the power plug before any maintenance or repair. Because there is a high-voltage danger in the control box, please turn off the power, and then open the control box after five minutes.
- Those marked with  in this manual are safety precaution points that shall be followed and strictly complied with to prevent unnecessary damage.

# 1. Installation Instructions

## 1.1. Specification

Controller Type	SU11G-G	Output voltage	176VAC—264VAC
Power freq	50Hz/60Hz	Max. output power	850W

## 1.2. Wiring and Grounding

The grounding engineering of the system must be properly conducted, and its construction must be carried out by the qualified electrical engineering personnel. Before the product is energized and put into operation, the AC input of the power socket must be safely and reliably grounded. The grounding line of the system is yellow-green line, and it must be reliably connected to the safe protection earth of the power grid to ensure safe operation and prevent abnormal conditions.

 <b>CAUTION</b>	<p><b>Ensure all power cord, signal wire and grounding wire not be pressed by other matter or over-twisted ,and not be too close to belt and belt wheel, keep 3cm-distance for safety.</b></p>
---	--

A 1Φ/220V power from a 3Φ/380V Power source Connection

 <b>CAUTION</b>	<p><b>If the system have no Neutral point, then this servo motor is not suitable for this connection.</b></p>
---	---

## 1.3. Motor Installation

**Step 1:** Mount lifting bracket. When motor installed under the machine table, as needed, to drill holes in the following diagrams (see Fig. 1-1 the example for USA base table) for the installation, mount lifting bracket.

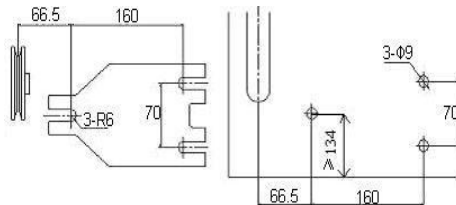

Fig.1-1 the example for USA base table

**Step 2:** Install the motor (see Fig.1-2) and then tighten the lifting bracket.

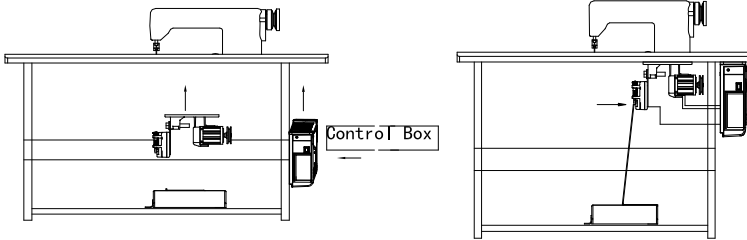

Fig.1-2

**1.4. Controller Installation**

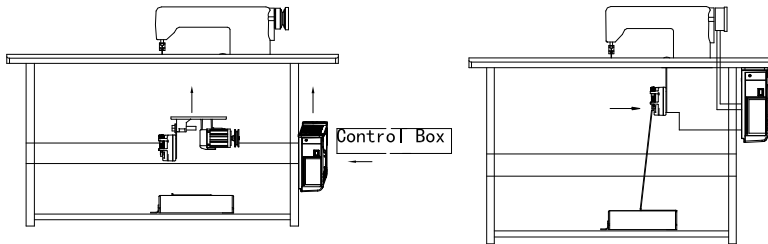

Fig.1-3

**2. Definition of controller interface**

Connections between control box and other accessories are illustrated in Fig.2-1. Plug these connectors into the corresponding sockets in control box.

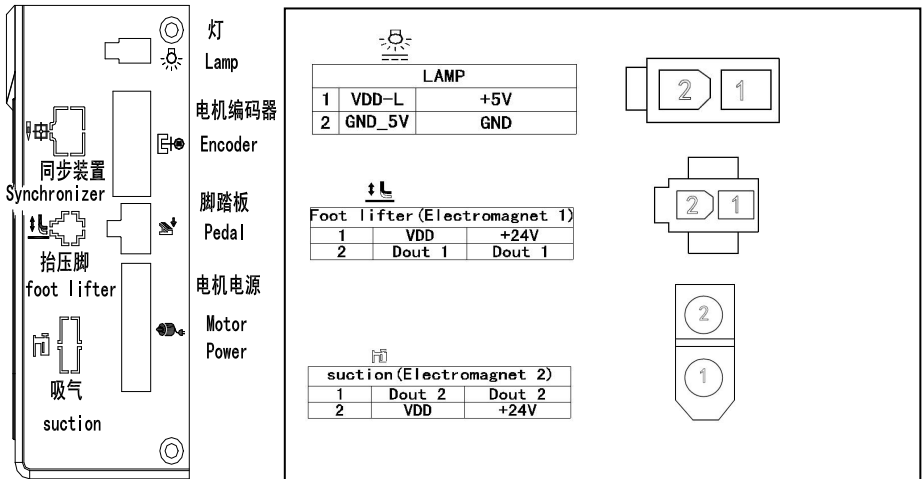

Fig.2-1 controller link

### 3. Operation Panel (HMI) Instruction

#### 3.1. Panel Instruction

SU11G-G operation Panel is divided into (See Fig3-1) digital tube area and key operation area. The digital tube area is positioned in the middle of the operation panel. It consists of 3 digital tubes, used to display function setting and parameters. There are 2 keys at the top of the digital tube area, they are "P" and "S". There are 3 keys at the bottom of the digital tube area and two LED lights are located above the lower right two keys, showing the corresponding function are open or closed.

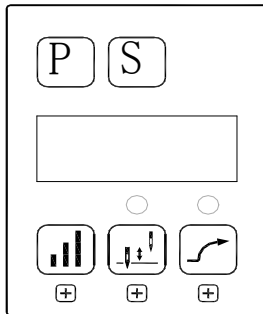



Fig.3-1 Panel Instruction

#### 3.2. Function of Key

Key Icon	Key name	Function description
	FUNCTION KEY	Combines with other keys to set a higher level of the parameter; the password interface confirmation and other interface cancel function. "P" key pressed one time to return to the initial interaction in the parameter modification interface, not to save the current parameters.
	SAVE	Confirm the operating (except the password interface),the system saves the current parameters in the parameter modification interface.
	HUNDRED KEYS	Adjustable speed.Increase the highest bit. In the technician parameter interface, it could increase the higher bit of the parameter. Combined with the P key, it enters into the technician index interface.

Key Icon	Key name	Function description
	STOP POSITION KEY	Select up/down stop position. It is also used to increase the middle bit of the digital value, each effective pressing once increase a numerical.
	SOFT START KEY	Select soft start function. It is also used to increase the lowest bit of the digital value, each effective pressing once increase a numerical.

**3.3. Digital interface instruction**

Digital interface is divided with three state : The idle state, the indexing status and data display state.

**3.3.1. Idle state :** When power on, it is the default display state.



Fig.3-2 idle state

**3.3.2. The indexing status has three cases**



Fig.3-3 technician index



Fig.3-4 monitor index



Fig.3-5 error playback index

**3.3.3. Data display state**

It shows different data according to the selected index - technician parameters, control parameters and error code.



Fig.3-6 data display state

**4. Use Instructions for Operator Panel**



**4.1. Shortcut set**

In the idle state interface, it can be used to set the soft start and stop position function directly.

**4.1.1. Soft start set**

In the idle state (Fig.3-2),press  (SOFT START KEY),the soft start function will be toggle between enable and disable.If enable the lamp above this key will be lightened (), otherwise the lamp will be off ().

**4.1.2. Stop position**

In the idle state (Fig.3-2),press  (STOP POSITION KEY),toggle between up and down stop position.The lamp lightened () shows that the needle will stop in the down position ,otherwise () the needle will stopped in the up position.

**4.2. Technical Mode**

In the application, to make the controller works in a better condition or to satisfy our own demand, we can adjust the technician parameters as the following steps.



Step 1: Under idle state, first press  (FUNCTION KEY) and hold on, then press , Two keys are pressed at the same time, digital tube display see figure  4-1, required to enter the password. The default password is 000.

Fig.4-1 password interface





Step 2: Press , ,  (SOFT START KEY), Modify the digital tube display to the correct password, and then press  (FUNCTION KEY). If the password is correct, enter the parameters modified index, see figure 4-2.



Fig.4-2 technical index









Step 3: Under parameters index, press  (STOP POSITION KEY),  (SOFT START KEY) to modify digital tube display to the needs of the technology parameters. Technical parameters see table 1. Index number is determined, press  (SAVE), enter to parameters of interface, see figure 4-3.



Fig.4-3 technical parameters

Step 4: Press  (HUNDRED KEYS),  (STOP POSITION KEY),  (SOFT START KEY) to modification of digital tube display to the needs of the technology parameters.



Step 5: After parameter modified, press  (SAVE), confirm the parameter modification and return to the index interface. If you don't want to save the changes by  (FUNCTION KEY), it will return to the idle interface.

Any time can press  (FUNCTION KEY) is returned to the free interface.

### 4.3. R&D parameter modification

First press  (FUNCTION KEY) and hold on, then turn the power switch, you can enter the R & D parameters; Other methods of operation with the technical parameters of operation.

### 4.4. Monitor mode

Step 1: Under idle state mode, first press  (FUNCTION KEY) and hold on, press  (STOP POSITION KEY). Two keys pressed at the same time, digital

tube display see figure 4.1, monitor index interface.



Fig.4-4 monitor index





Step 2: Under parameters index, press  (STOP POSITION KEY),  (SOFT START KEY) to modification of digital tube display to the needs of monitoring index number . Monitor index see table 2. Index number is determined, press  (SAVE) ,enter to monitor parameters of interface, see figure 4-5.





Fig.4-5 monitor parameters

Step 3 : In the monitoring parameter interface, in addition to press  (FUNCTION KEY) of any key, returns to the monitoring parameter index interface. Press  (FUNCTION KEY) , returned to the idle state of interface.

Step 4 : Repeat step 2 for other monitoring parameters or step 3 exits to monitor mode.

#### 4.5. Error playback

The controller could save the recent 8 error occurrence. Index 0 shows the most recent fault code. Index 1 stores the error code occurred before index 0's error. Fault code and fault relation, see table 3.

Step 1: In idle state , first press  (FUNCTION KEY) and hold on, then press  (SOFT START KEY) ,Two keys are pressed at the same time, digital tube display see figure 4-6.

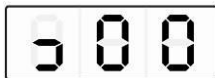

Fig.4-6 error playback index









Step 2: Under error playback index, press  (STOP POSITION KEY) 、  (SOFT START KEY) to modify digital tube display to the needs of error playback index number (0-7) . Error index number display correctly, press  (SAVE) entered the error recording interface, view the index number of the recorded fault code, see figure 4-7.





Fig.4-7 fault code display

Step 3 : In the failure code display interface, press any key except  (FUNCTION KEY) , return to error playback index interface. Press  (FUNCTION KEY) returned to the idle state of interface.

#### 4.6. Automatic test

In the idle state interface,The first press  (FUNCTION KEY)and  (SAVE) combination , then step on the pedal controller immediately enter into the automatic test status. The controller will run according to setting about test mode and test time operation, until the end of test.Press  (FUNCTION KEY)and  (SAVE) combination again the controller will exit the test mode until the run time exhausted.

#### 4.7. Transmission ratio and the initial angle test

Under idle state,press  (FUNCTION KEY)and  (HUNDRED KEYS) combination. You can enter the technical parameter:

The initial angle test: P18 parameters adjusted to 2 (test the initial angle),

the pedal is pressed to start the test, the test after the parameter back to 0 to (normal operation mode).

Transmission ratio test: P18 parameter adjustment 3 (test drive), depressing the pedal to start the test, the test after the parameter back to 0 (normal operation mode).

#### 4.8. Operation note

To make the system running at peak performance, the customers for the first time using the recommended test again the initial angle and transmission ratio. R & D parameters so as not to be freely modified, and you incorrectly modify the normal use.

Table 1: Technician mode parameter :

classification	Index No.	Default	Rang	Comment
Speed	P00	20	10~80	Minimum sewing speed (display value*10)
	P01	350	20~700	Maximum sewing speed (display value*10)
	P02	2	1~9	Soft start stitch number
	P03	13	10~80	Soft start maximum sewing speed (display value*10)
	P04	13	1~20	System accelerate sensitivity ( Direct drive transmission can be set up to a large value ; belt transmission don't set large value or too much noise and vibration. This parameter do not affect the electrical )
	P05	20	1~80	System decelerate sensitivity ( Direct drive transmission can be set up to a large value ; belt transmission don't set large value or too much noise and vibration. This parameter do not affect the electrical )
Pedal	P08	2	0 / 1 / 2 / 3	Pedal Curve mode setup: 0: Auto Calculated liner Curve (According to the highest speed automatic computation)

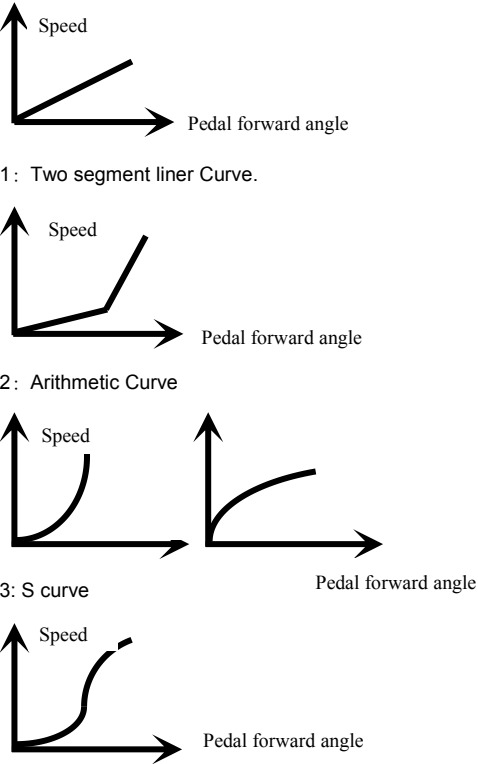
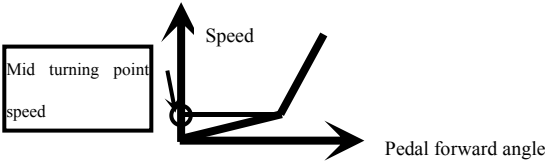
			 <p>Speed</p> <p>Pedal forward angle</p> <p>1: Two segment liner Curve.</p> <p>Speed</p> <p>Pedal forward angle</p> <p>2: Arithmetic Curve</p> <p>Speed</p> <p>Pedal forward angle</p> <p>3: S curve</p> <p>Speed</p> <p>Pedal forward angle</p>
	<p><b>P09</b></p>	<p><b>300</b></p>	<p>20~400</p> <p>Two segment controls the speed slope : mid turning point speed RPM ( two segment of turning point speed ) , the parameter[8] set to 1 effective。</p>  <p>Mid turning point speed</p> <p>Speed</p> <p>Pedal forward angle</p>
<p>Pedal</p>	<p><b>P10</b></p>	<p><b>800</b></p>	<p>0~999</p> <p>Two segment controls the speed slope : mid turning point of pedal Simulated value, the parameter[8] set to 1 effective, the value is between[15]and[16].</p>

				<p>Speed</p> <p>Pedal forward angle</p> <p>Mid turning point of pedal Simulated</p>
P11	1	1 / 2	<p>Arithmetic Curve supplementary parameter : the parameter[8] set to 2 effective, 1: Square (the low speed control is very well, slow start after fast) ;</p> <p>Speed</p> <p>Pedal forward angle</p> <p>2: Square root (Responding speed is fast, fast start after slow) ;</p> <p>Speed</p> <p>Pedal forward angle</p>	
P12	190	0~999	Up stop needle position after pedal ( set value shall not be higher than 【13】 )	
P13	460	0~999	Pedal back mid position ( set value between 【12】 and 【14】 )	
P14	480	0~999	Pedal step upon running position ( set value between 【13】 and 【15】 )	
P15	680	0~999	Pedal low speed running position ( upper ) ( set value between 【14】 and 【16】 )	
P16	940	0~999	Pedal simulation the largest of value ( set value shall not be less than 【15】 )	

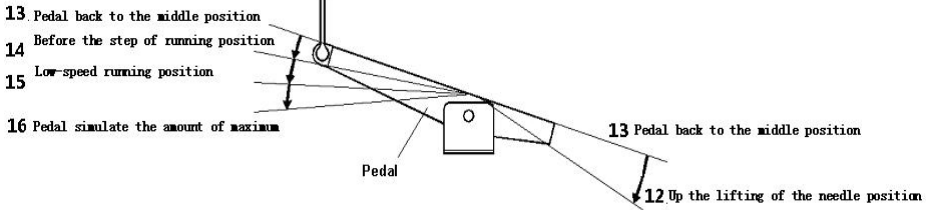

custom setup 1	P17	1	0 / 1	Run to up needle position after Power on: 0: no action 1: action
	P18	0	0 / 1 / 2 / 3/4	Special Running Mode setup: 0: free sewing mode ; 1 : simple sewing mode ; ( without stopping operation mode in the synchronous sensor fault cases using ) ; 2: calculate initial angle of motor (do not uninstall strap); 3: calculate motor/machine head run rate mode ;(synchronizer, do not uninstall strap)4: The control system only in the current loop control running, speed open-loop.
	P21	40	10~80	On the needle lifting speed
	P22	350		Automatic test speed
	P25	0	0 / 1	Electric steering: 1: reversal; 0 : forward
Machine head parameter	P26	100	10~500	motor/machine head run rate: 0.001 (if automatic calculation of motor/machine head run rate has done, the Parameter value in control box maybe different with that in HMI) ( display value * 10 )
	P27	0	0~359	Up needle position mechanical angle
	P28	175	0~359	Down needle position mechanical angle
Start/Stop mode	P31	Stop position		0: up needle position ; 1: down needle position
	P32	Soft start		0: Off; 1: On.
Automatic test	P33	0	1	Automatic test mode select : 0: needle NO.; 1: time
	P34	30	0~999	Automatic test total time setting (10 minute)
	P35	90	1~999	Running time (0.1second) / needle NO.

	<b>P36</b>	<b>10</b>	1~999	Stop time (0.1second)
Parameter saves recovery	<b>P37</b>	<b>0</b>	0~11	Parameter reload (0: Lockstitch straight drive; 3: thick material; 6: 360 Lockstitch straight drive; 7: 360 lockstitch belt; 10: Nested package stretch sewing; 11: roller; 12: Double needle direct drive; 13: Overedge belt machine; 14: Nested package overedge sewing)
	<b>P38</b>		0-1	Parameter transfer : 1:read data ; 0:write data
	<b>P73</b>	<b>280</b>	0~999	Foot lifter position
	<b>P74</b>	<b>10</b>	0~999	Pedal foot lifter confirm time (10ms)
	<b>P75</b>	<b>10</b>	0~999	Pedal foot down confirm time (10ms)
	<b>P76</b>	<b>1</b>	0~999	Electromagnet 1 chopping open time
	<b>P77</b>	<b>1</b>	0~999	Electromagnet 1 chopping close time
	<b>P78</b>	<b>80</b>	0~600	Electromagnet 1 solenoid protect time(100ms)
	<b>P79</b>	<b>800</b>	0~999	Electromagnet 1 full output time
	<b>P80</b>	<b>1</b>	0~3	Electromagnet 1 function 0:off; 1: foot lifter; 2:sunction: 3:+24V output
	<b>P81</b>	<b>1</b>	0~999	Electromagnet 2 chopping open time
	<b>P82</b>	<b>1</b>	0~999	Electromagnet 2 chopping close time
	<b>P83</b>	<b>80</b>	0~600	Electromagnet 2 solenoid protect time(100ms)
	<b>P84</b>	<b>800</b>	0~999	Electromagnet 2 full output time
	<b>P85</b>	<b>2</b>	0~3	Electromagnet 2 function 0:off; 1: foot lifter; 2:sunction: 3:+24V output
	<b>P86</b>	<b>20</b>	20~300	Plus stitch speed
	<b>P87</b>	<b>150</b>	1~999	Plus half stitch delay time
	<b>P88</b>	<b>150</b>	1~999	Plus a stitch delay time
	<b>P89</b>	<b>0</b>	0~2	Input 1 function 0:off; 1: safe SW.; 2:plus stitch:

	<b>P90</b>	<b>0</b>	0~1	Input 1 effective level
--	------------	----------	-----	-------------------------

Table 2: Monitor mode parameter (show only the highest of 3 bit)

Index NO.	Comment	until
<b>0</b>	Bus voltage	V
<b>1</b>	Mechanical speed	10r/m
<b>2</b>	Q axis current	0.01A
<b>3</b>	Initial angle	degree
<b>4</b>	Mechanical angle	degree
<b>5</b>	Pedal analog sampling value	—
<b>6</b>	Transmission ratio	0.001
<b>7</b>	Version number	

Table 3: error code

error code	Error Definition	Solution
01	Hardware overload	Shut down the controller, Re-power it after 30s interval, if the controller still works abnormally, replace it and inform manufacturer.
02	Software overload	
03	Low voltage	Shut down the controller, check input power voltage, if the voltage is lower than 190V, please restart the controller after the voltage is normal, if the controller still work abnormally after the voltage is recovered to the normal level, please replace it and inform manufacturer.
04	Voltage is too high while stopping	Shut down the controller, check the input voltage is high (above 245V). If the power supply voltage is high, Restart controller after recovery, if the controller still cannot work normally please replace it and inform manufacturer.
05	Voltage is too high during Operation	
07	Current detection loop circuit fault	Shut down the controller, Re-start it 30s interval, if the controller still can not work normally replace it and inform manufacturer.
08	Motor stalled	Shut down the controller, check the motor power cord whether it is broken off, loosen, damaged, or be tangled on the machinery by other stuffs. Restart controller after recovery, if the controller still cannot work normally please replace it and inform manufacturer.

09	Dynamic Braking failure	Shut down the controller, check the motor power cord whether it is loosen , which is tightly inserted after restart controller , if the controller still cannot work normally please replace it and inform manufacturer.
11	Synchronizer failure	Shut down controller power, check if the connection wire between synchronizer and controller is loosened; if the controller still work abnormally after restart please replace it and inform manufacturer.
12	Initial motor angle detection failure	Restart for 2~3 times, if the controller still work abnormally, Please inform manufacturer.
13	HALL failure	Shut down the controller, check the motor power cord whether it is loosen , return normal after restart controller , if the controller still cannot work normally please replace it and inform manufacturer.
14	DSP access failure EEPROM	Shut down the controller, Re-start it1 attempts, if the controller still work abnormally, Please inform manufacturer.
15	Motor over speed protection	Shut down the controller, Re-start it 30s interval, if the controller still work abnormally, Please inform manufacturer.
16	Irregular motor operation	Shut down the controller, Re-start it 30s interval, if the controller still work abnormally, Please inform manufacturer.
18	Motor overload	Shut down the controller, Re-start it 30s interval, if the controller still work abnormally, Please inform manufacturer.