目 录

1 安全	4
Safety	
1.01 规范	4
Criterion	
1.02 一般安全说明	4
General notes on safety	
1.03 注意安全标志	5
Safety symbols	
1.04 工作中的特殊注意事项	5
Important points for the user	
1.05 操作人员和专业人员	6
Operating and specialist personnel	
1.05.01 操作人员	6
Operating personnel	
1.05.02 专业人员	7
Specialist personnel	
1.06 危险警告	7
Danger	
2 应用规定	8
Proper use	
3 缝纫机机头的规格	9
Specifications of the machine head	
4 缝制图案一览表	10
STITCH PATTERN TABLE	
5 安装	11
INSTALLATION	
5.01 缝纫机机头的安装	11
Installation of the sewing machine head	
5.02 膝提的安装	12
Attaching the knee-lifter	
5.03 膝提升高度的调整	12
Adjusting the height of the knee lifter	
5.04 线架的安装	12
Installing the thread stand	
5.05 操作盘的安装	13
Installing the operation panel	
5.06 加油	13
Lubrication	
5.07 试运转	13
Test run	
6 缝制前的准备	15
PREPARATION BEFORE SEWING	
6.01 机针的安装	15
Inserting the needle	
6.02 梭壳的安装方法	15
Removing the bobbin case	

6.03	底线的卷线方法	16
	Winding the bobbin thread	
6.04	梭心的放入方法	18
	Placing the bobbin case and the bobbin	
7	缝制	19
	SEWING	
7.01	线张力的调整方法	19
	Adjusting the thread tension	
7.02	压脚压力的调整	20
	Adjusting the pressure of the presser foot	
7.03	拨杆手动倒缝	20
	One-touch type reverse feed stitching mechanism	
7.04	关于手持开关	22
	Hand switch	
8	标准调整	23
	STANDARD ADJUSTMENT	
8.01	旋梭油量的调整	23
	Adjusting the amount of oil in the hook	
8.02	机头面部加油量的调整	24
	Adjusting the amount of lubricating to face plate section	
8.03	压脚杆高度的调整	24
	Adjusting the height of the presser bar	
8.04	压脚微量浮起的调整	25
	Adjusting the micro-lifting mechanism of the presser foot	
8.05	送布牙的高度、倾斜	25
	Height and inclination of the feed dog	
8.06	旋梭的安装、拆卸	26
	Attaching/removing the hook	
8.07	针高度（预校验）	27
	Needle height (preliminary adjustment)	
8.08	针杆提升行程、旋梭距离和旋梭定位钩	27
	Needle rise, hook clearance and bobbin case position stop	
8.09	机针停止位置的调整	28
	Adjusting the stop position of the needle	
8.10	切线的调整	29
	Adjusting the thread trimmer	
8.11	上线挑线装置的调整	30
	Adjusting the needle thread feeding device	
9	维修和保养	31
	MAINTENANCE AND MAINTENANCE	
9.01	保养间隔	31
	Maintenance intervals	
9.02	机器的清洁	31
	Cleaning the machine	
9.03	机器上油	32
	Oiling the machine	

9.04 冷却风扇（安装于底护罩）	33
Cleaning the cooling fan installed on the under cover	
9.05 旋梭部的清扫	33
Cleaning the hook section	
9.06 旋梭轴油芯的更换方法	34
Replacing procedure of the hook shaft oil wick	
9.07 关于专用润滑脂的涂抹	34
Applying the exclusive grease	

1 **安全**
Safety

1.01 **规范**

Criterion

- 本机器是按照在符合制造商声明中给出的中国制造的。
- 对本使用说明书的补充，请您注意通用有效的、包括机器营运所在国家内的有关法律和其它的规定及法规，以及有效的环保规定；始终要注意当地同业工伤事故联合的规定，或者其它监督机构的规定！
- This machine is constructed in accordance with the Chinese regulations contained in the conformity and manufacturer's declarations.
- In addition to this Instruction Manual, also observe all generally accepted, statutory and other regulations and legal requirements and all valid environmental protection regulations! The regionally valid regulations of the social insurance society for occupational accidents or other supervisory organization is are to be strictly adhered to!

1.02 **一般安全说明**

General notes on safety

- 机器只能由受过培训的操作人员读懂使用说明之后操作！
- 在试车调试之前一定要首先阅读电机生产厂家的安全提示和使用说明！
- 请注意在机器上的危险警告和安全提示！
- 只允许根据机器的规定操作机器，并且不得在没有所属的保护装置的情况下，使机器运行，同时要注意有关的安全规定。
- 在更换缝纫工具（例如：机针、压脚、针板和线梭）、穿线、离开工作位置，以及对机器进行维修保养时，必须操作总开关或将电源插头拉下，以切断机器的电源！
- 每天的保养工作只能由受过相应培训的人员完成！
- 不允许在带电的部件和设备上工作！
- 特殊情况根据 EN50110 规定执行。
- 所有机器的改建和修改工作只允许在满足相应的安全的条件下进行！
- 在修理工作中只允许使用我们所允许的备件！明确指出的是，所有不是由我们供货的备件和附件都未经我们检查，也没有被我们批准使用。装入和/或使用这些产品可能在一定的情况下会对机器的设计特性造成负面改变。对由于使用非原装件所造成的损失，我们不负任何责任。
- This machine may only be operated by adequately trained operators and only after having completely read and understood the Instruction Manual!
- All Notes on Safety and Instruction Manuals of the motor manufacturer are to be read before operating the machine!
- The danger and safety instructions on the machine itself are to be followed!
- This machine may only be used for the purpose for which it is intended and may not be operated without its safety devices. All safety regulations relevant to its operation are to be adhered to.
- When exchanging sewing tools (e.g. needle, roller presser, needle plate and bobbin), when threading the machine, when leaving the machine unattended and during maintenance work, the machine is to be separated from the power supply by switching off the On/Off switch or by removing the plug from the mains!
- Everyday maintenance work is only to be carried out by appropriately trained personnel!

- Repairs and special maintenance work may only be carried out by qualified service staff or appropriately trained personnel!
- Work on electrical equipment may only be carried out by appropriately trained personnel!
- Work is not permitted on parts and equipment which are connected to the power supply! The only exceptions to this rule are found in the regulations EN 50110.
- Modifications and alterations to the machine may only be carried out under observance of all the relevant safety regulations!
- Only spare parts which have been approved by us are to be used for repairs! We expressly point out that any replacement parts or accessories which are not supplied by us have not been tested and approved by us. The installation and/or use of any such products can lead to negative changes in the structural characteristics of the machine. We are not liable for any damage which may be caused by non-original parts.

1.03 注意安全图标

Safety symbols



危险位置!

特别注意点!

Danger!

Points to be observed!

对操作人员或专业人员有受伤的危险!



Danger of injury for operating and specialist personnel!

注意!

Caution

不允许在没有护指器和保护装置的情况下工作!

在穿线、换梭芯、换针、清洁等工作之前, **关闭总开关!**

Do not operate without finger guard and safety devices.

Before threading, changing bobbin and needle, cleaning etc.

Switch off main switch.

1.04 工作中的特殊注意事项

Important points for the user

- 使用说明书属于机器的一部分, 因此, 操作人员必须可以随时取用。在首次试车调试之前, 必须阅读使用说明书。
- 必须对操作人员和专业人员进行有关机器的防护装置及安全工作方面的培训。
- 机器营运者有责任保证机器在正常的无故障状态下运作。
- 机器营运者必须注意, 不许拆除任何安全装置以及使它们失效。
- 机器营运者必须注意, 只允许被授权的人员在机器上工作。
- This Instruction Manual is an integral part of the machine and must be available to the operating personnel at all times.
- The Instruction Manual must be read before operating the machine for the first time.
- The operating and specialist personnel is to be instructed as to the safety equipment of the machine and regarding safe work methods.

-
- It is the duty of the user to only operate the machine in perfect running order.
 - It is the obligation of the user to ensure that none of the safety mechanisms are removed or deactivated.
 - It is the obligation of the user to ensure that only authorized persons operate and work on the machine.

其它的询问可以从负责的销售处获得答复。

Further information can be obtained from our Sales Department.

1.05 **操作人员和专业人员**
Operating and specialist personnel

1.05.01 **操作人员**
Operating personnel

操作人员指的是那些负责机器的机器准备、操作和清洁以及排除缝纫范围故障的人员。

Operating personnel are persons responsible for the equipping, operating and cleaning of the machine as well as for taking care of problems arising in the sewing area.

操作人员有责任注意和遵守下列事项:

- 在所有工作中注意使用说明中所列的安全提示!
- 绝不许使用任何影响机器安全生产的工作方法
- 穿贴身服装, 不许带首饰, 如项链和戒指!
- 必须保证, 只让被授权的人员在机器的危险区内逗留!
- 在机器上出现影响机器安全生产的变化时, 立即向机器营运者报告!

There operating personnel is required to observe the following points and must:

- Always observe the Notes on Safety in the Instruction Manual!
- Never use any working methods which could adversely affect the safety of the machine!
- Not wear loose-fitting clothing or jewelry such as chains or rings!
- Also ensure that only authorized persons have access to the potentially dangerous area around the machine!
- Always immediately report to the person responsible any changes in the machine which may limit its safety!

1. 05. 02 专业人员

Specialist personnel

专业人员指的是那些在电/电子和机械方面受过专业训练的人员。他们负责机器的润滑、保养、修理和校验工作。

Specialist personnel are persons with a specialist education in the fields of electrics, electronics and mechanics. They are responsible for the lubrication, maintenance, repair and adjustment of the machine.

专业人员有责任注意和遵守下列事项：

- 在所有工作中注意使用说明中所列的安全提示！
- 在校验和修理工作开始之前必须关闭总开关，并且加上防止重新开机保险！
- 不许在带电的零件和设备上工作！特殊情况按 EN 50110 规定处理。
- 修理和保养工作完成之后，必须将防护罩生新盖好！
- The specialist personnel is obliged to observe the following points and must:
- Always observe the Notes on Safety in the Instruction Manual!
- Switch off the On/Off switch before carrying out adjustments or repairs, and ensure that it cannot be switched on again unintentionally!
- Wait until the luminous diode on the control box is no longer blinking or on before beginning adjustment or repair work.
- Never work on parts which are still connected to the power supply! Exceptions are explained in the regulations EN 50110.
- Replace the protective coverings and close the electrical control box after all repairs or maintenance work!

1. 06 危险警告

Danger



机器运作过程中，必须在机器的前后各保留 1m 的自由工作范围。以保证人员能够随时地、不受阻地接近机器。

A working area of 1 meter is to be kept free both in front of and behind the machine while it is in operation so that it always easily accessible.



在缝纫过程中，不许在缝纫针区域抓取任何东西！有被针伤的危险！

Never reach into the sewing area while sewing!

Danger of injury by the needle!



调整工作过程中，不许在工作台上放任何物品！

物品有被卡住或者被甩走的可能！

有被四下乱飞的物品伤害的危险！

Never leave objects on the table while adjusting the machine settings! Objects can become trapped or be slung away ! Danger of injury!



机器只允许在防护盖 1 关闭的情况下运行！
有被旋转的挑线杆伤害的危险！
Only operate the machine with cover 1 closed!
Danger of injury from the rotating take-up lever!



不许开动没有护指器 2 的机器！
有被针伤的危险！
Do not operate the machine without the finger guard 2!
Danger of injury by the needle!



机器不许在没有起动闭锁 3 的情况下运行！
有被机器意外起动伤害的危险！
Do not operate the machine without start inhibitor 3!
Danger of injury by the needle!



机器不许在没有防护罩 4 的情况下运行！
有被运动的部件伤害的危险！
Do not operate the machine without cover 4!
Danger of injury from moving parts!

2

应用规定

Proper use

2290 是一种带有下送料牙和大旋梭的人字线缝高速缝纫机。

2290 is high-speed, zigzag sewing machine with bottom feed and a large hook.

这种缝纫机用于在服装和内衣工业中缝制双线锁式人字线缝。

The machine is used for producing zigzag lockstitch seams in the clothing and linen industry.



任何未经机器制造商准许的应用，都被视为违反规定！对由于违反规定的应用引起的损失，机器制造商不负任何责任！属于应用规定的内容也包括遵守由机器制造商所给出的各种操作方法、保养措施、校验方法和修理措施！

Any and all uses of this machine which have not been approved of by the manufacturer are considered to be inappropriate! The manufacturer cannot be held liable for any damage caused by the inappropriate use of the machine! The appropriate use of the machine includes the observance of all operational, adjustment, maintenance and repair measures required by the manufacturer!

3 缝纫机机头的规格 Specifications of the machine head

型式 (微量加油型) Model (Minute-quantity, Lubricating type)	2438
用途 Application	薄料~中厚料 Light-weight materials to medium-weight materials
最高转速 Max. sewing speed	5000rpm
最大摆幅 Max. zigzag width	10 mm
最大送布量 Max. feed pitch	正逆 5mm(normal/reverse feed)
缝制图案 Stitch pattern	14 种 20 图案 14type20patterns
使用机针 Needle	蓝狮 DPX5#10
使用机油 Oil used	10#白油
切线 Thread trimmer	有 With
送布方式 Feed method	标准送布 (电子控制方式) Standard feed(Computer controlled system)

1. 出货时最高缝制速度设定为 3000prm.
The max .sewing speed is set to 3000prm at the time of delivery
2. 标准出厂设置为2mm.
The standard factory setting is 2mm.

4. 缝制图案一览表

STITCH PATTERN TABLE

图案名称 Name of pattern		针迹图案 Stitch pattern	图案针数 Number of stitches for pattern	最大摆幅 Max. zigzag width	备注 Remarks
直线 Straight stitch			1	10	
2点锯齿缝 2-Standard zigzag stitch			2		
3点锯齿缝 3-Standard zigzag stitch			4		
4点锯齿缝 4-Standard zigzag stitch			6		
右贝壳装饰 Scallop right	标准贝壳 Standard scallop		24		
	月牙贝壳 Crescent scallop				
	均等贝壳 Equal-width scallop				
	均等贝壳 Equal-width scallop		12		
左贝壳装饰 Scallop left	标准贝壳 Standard scallop		24		
	月牙贝壳 Crescent scallop				
	均等贝壳 Equal-width scallop				
	均等贝壳 Equal-width scallop		12		
暗缝针迹(右) Blind stitch(right)			2+A		
暗缝针迹(左) Blind stitch(left)					
自设图案 Custom pattern			500		
T型线迹(左) T stitch(left)			3		
T型线迹(右) T stitch(right)					
花样1 Pattern1			6		
花样2 Pattern2					
花样3 Pattern3					
花样4 Pattern4					

5 安装 INSTALLATION



注意

1. 安装缝纫机必须让受过训练的技术人员进行。
 2. 搬运缝纫机时，必须由 2 人以上来进行，移动时请使用台车等用具。
 3. 为了防止缝纫机的突然起动造成以外事故，全部安装结束之前，请不要插上电源插头。
 4. 为了防止漏电造成事故，请一定连接上地线。
 5. 请一定安装上安全保护外罩、手指防护器等。
1. Perform the installation of the sewing machine by the technical personnel who have been trained.
 2. Be sure to perform the work with two persons or more when transporting the sewing Machine and use a lorry when moving it.
 3. To prevent personal injury caused by abrupt start of the sewing machine, do not connect power plug until the set-up of the sewing machine is completed.
 4. Be sure to earth the ground wire to prevent personal injury caused by leak.
 5. Be sure to attach safety protection cover, finger guard, etc.

5.01 缝纫机机头的安装 Installation of the sewing machine head

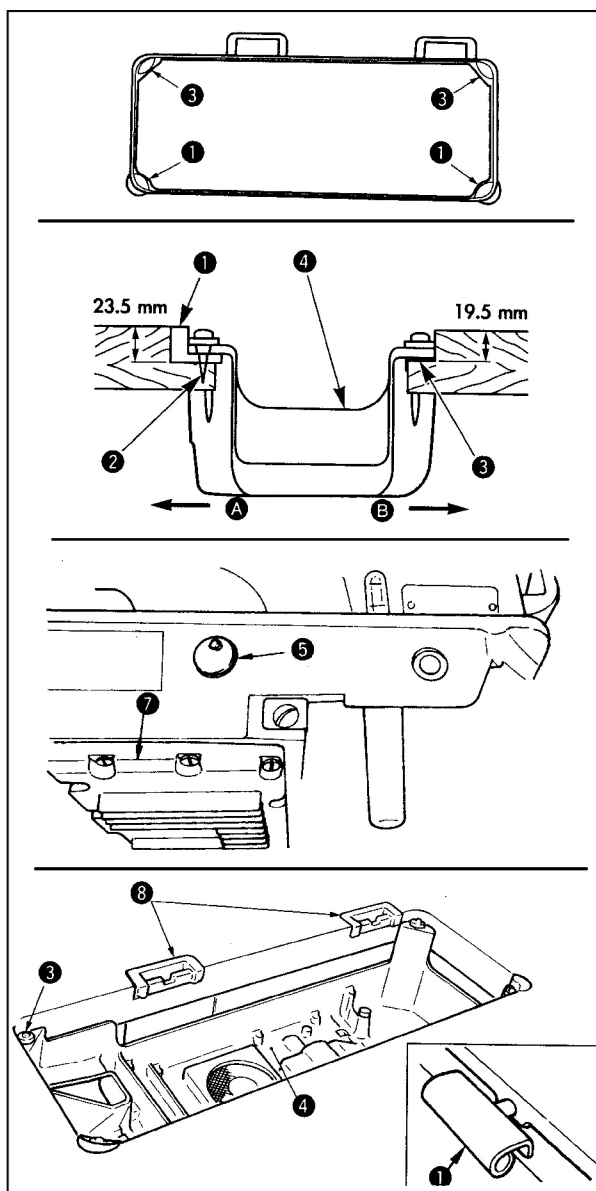

(1) 底槽的安装

Installing the under cover

- 1) 把底槽支到即台沟的四角上。
The under cover should rest on the four corners of the machine table groove.
- 2) 用螺丝②把前侧 A 的 2 个头部橡胶支座①钉到机台的伸出部，用黏接胶黏接固定好铰链侧 B 地个头部橡胶支座③，然后把底槽④放上去。
Fix two rubber seats ① on side A using nails ② as illustrated above. Fix two cushion seats ③ on side B using A rubber-based adhesive. Then place under cover ④ on the fixed seats.
- 3) 请卸下机头的放气盖⑤。(搬动机头时，请一定把放气盖⑤盖上。
Remove air vent cap ⑤ attached to the machine bed. (Be sure to attach cap ⑤ when transporting the machine head in the state that the machine head is removed from the machine table.
- 4) 把铰链①放到机台的孔上，对准台板橡胶支座③，把头部放到四角的机头橡胶垫③上。
Fit hinge ① into the opening in the machine bed, and fit the machine head to table rubber hinge ③ before placing the machine head on cushions ③ on the four corners.

5.02 膝提的安装

Attaching the knee-lifter

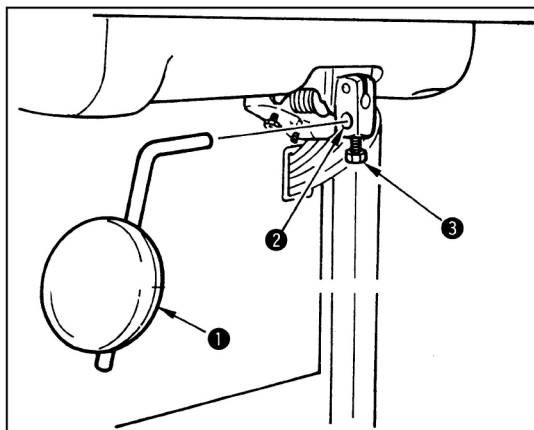

把膝档①插入安装孔②，用螺栓③固定。
Insert knee-lifter into attaching hole ② and tighten it with bolt ③.

5.03 膝提升高度的调整

Adjusting the height of the knee lifter

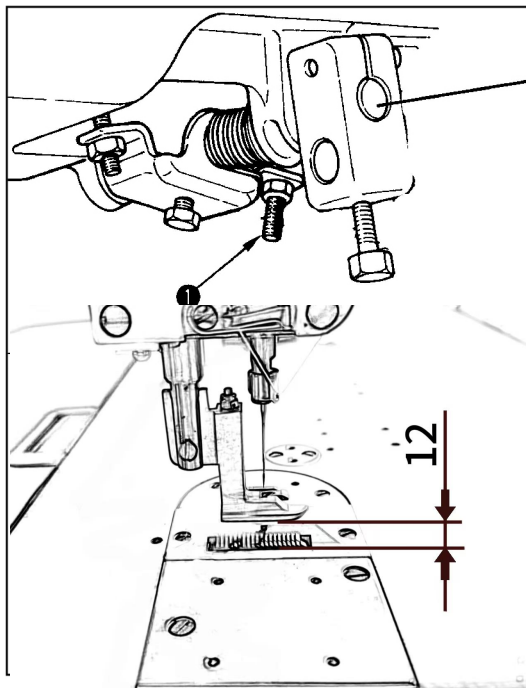

- 1) 膝提升压脚的标准高度为 12mm.
The standard height of the presser foot lifted using the knee lifter is 12 mm.

5.04 线架的安装

Installing the thread stand

5.05 操作盘的安装

Installing the operation panel

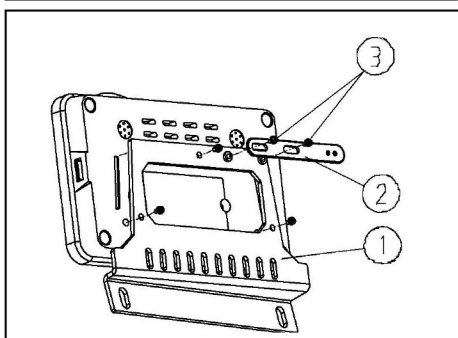
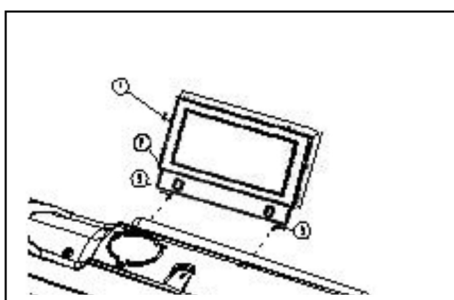

- 1) 使用已经安装到操作盘安装架②上的螺丝③把操作盘①安装到缝纫机机头。
- 1) Install operation panel① on the machine head using screws③ which have been assembled to panel installing bracket②.

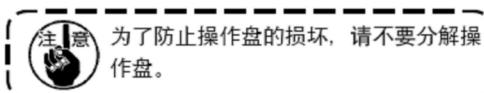

- 2) 使用螺丝③把穿线支架②安装到操作盘①上
- 2) Install threading bracket② on the operation pane① by using the screw③

5.06 加油

Lubrication



注意

1. 为了防止缝纫机的突然起动造成事故, 加油结束之前, 请不要连接电源插头。
2. 为了防止炎症或斑疹, 如果油沾到眼睛或身上后, 请立即洗净。
3. 误食油后有可能发生腹泻或呕吐。请把油放到小孩子拿不到的地方。
1. Do not connect the power plug until the lubrication has been completed so prevent accidents due to abrupt start of the sewing machine.
2. To prevent the occurrence of an inflammation or rash, immediately wash the related Portions if oil adheres to your eyes or other parts of your body.
3. If oil is mistakenly swallowed, diarrhea or vomiting may occur. Put oil in a place where children cannot reach.

5.07 试运转

Test run

(1) 打开电源

Turn ON the power



注意

1. 连接电源电缆线之前, 请再次确认电源电压规格。
2. 确认了电源开关关闭之后, 再把电源电缆线插连接到电源插座上。
3. 请一定连接地线。
4. 打开电源后蜂鸣器立即响个不停时, 有可能是电缆连接有错误或电源电压有错误, 请立即关闭电源。
1. check again the power voltage before connecting the power cord.
2. check that the power switch is turned OFF and connect the power cord to the power receptacle.
3. Be sure to connect the earth wire.
4. case where the buzzer keeps beeping immediately after turning ON and the power There is a possibility of the wrong connection of cord or wrong power voltage. Turn OFF the power.

1) 1) 驱动器上电，当针杆不在上针位时，出现如下界面：

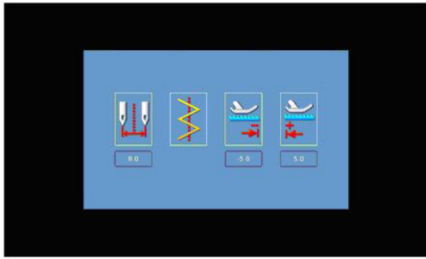

1) Switch on the driver, when the needle bar not in the needle position, it will appear below interface:

2) 转动手轮，让针杆移动到上针位，系统会根据上次掉电前的界面，选择进入如下界面，然后完成摆针找零的操作：

花样选择界面：

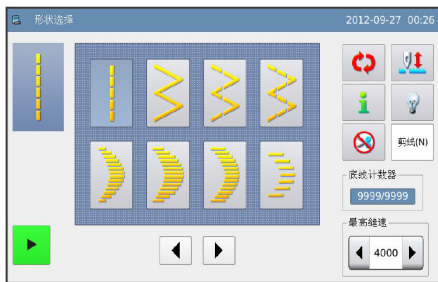

2) Run the hand wheel to move the needle bar to the top needle position, the system will choose to enter into below interface according to the one before the power off at last time, then finish the operation finding the "0" position of the swing needle:

Pattern select interface:

(2) 踏板操作

How to operate the pedal

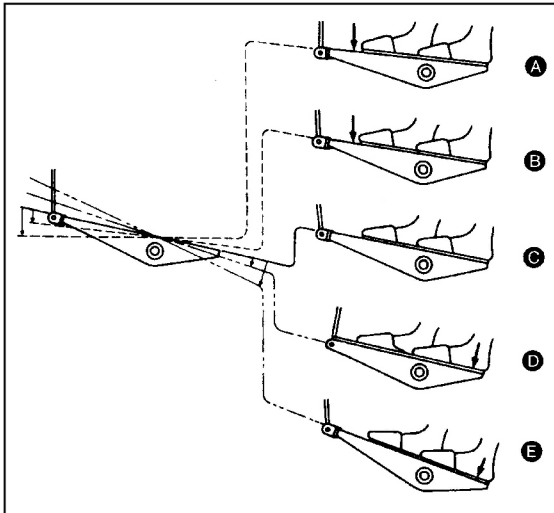

踏板有 4 级操作

- 1) 向前轻轻地踩踏板之后为低速缝制 B。
- 2) 在继续向前踩踏板之后为高速缝制 A。（但是，自动倒缝开关被设定时，倒缝结束之后再高速缝制）
- 3) 轻轻地踩踏板，脚踩在踏板上返回缝纫机停止 C。
- 4) 向后强力踩踏板之后缝纫机做切线动作 E。向后轻轻地踩踏板之后缝纫机做压脚提升动作 D，再继续向后踩踏板之后缝纫机做切线动作。

The pedal is operated in four stages.

- 1) Lightly depress the front part of the pedal for low-speed operation B.
- 2) Further depress the front part of the pedal for high-speed operation mode after the completion of reverse feed stitching if the automatic reverse feed stitching function is specified with the corresponding switch.)
- 3) Bring the pedal back to its neutral position, and the sewing machine will stop running C.
- 4) Strongly depress the back part of the pedal, and the thread trimmer will be actuated E. Lightly depress the back part of the pedal, and the presser foot will go up D. Further depress the back part of the pedal, and the thread trimmer will be actuated.

6 缝制前的准备 PREPARATION BEFORE SEWING

6.01 机针的安装 Inserting the needle

	注意 为了防止突然的起动造成人身事故，请关掉电源，确认马达完全停止后进行操作。 To protect against possible personal injury due to abrupt start of the machine, be sure to start the following work after turning the power off and ascertaining that the motor is at rest.
---	---

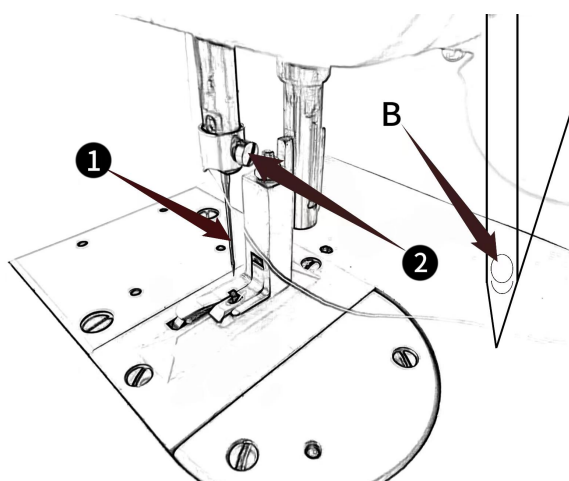

- 1) 转动手轮，把机针上上到最高的位置。
- 2) 拧紧机针固定螺钉②，把机针①的长槽部 B 转到前面。
- 3) 把机针向箭头方向深深的插进。
- 4) 拧紧机针固定螺丝②。
- 5) 确认机针的长槽 B 是否朝向前面。

- 1) Turn the hand-wheel by hand to raise the needle to its highest position.
- 2) Loose the needle clamp screw ①. Hold the needle so that the long groove ② on the needle is facing exactly toward you.
- 3) Insert the needle deep into the hole of the needle bar in the direction of the arrow until it will go no further.
- 4) Securely tighten the screw ②
- 5) Confirm that the long groove B on the needle faces toward you.

6.02 梭壳的安装方法 Removing the bobbin case

	注意 为了防止突然的起动造成人身事故，请关掉电源，确认马达完全停止后进行操作。 against possible personal injury due to abrupt start of the machine, be sure to start the following work after turning the power off and ascertaining that the moto is at rest.
---	---

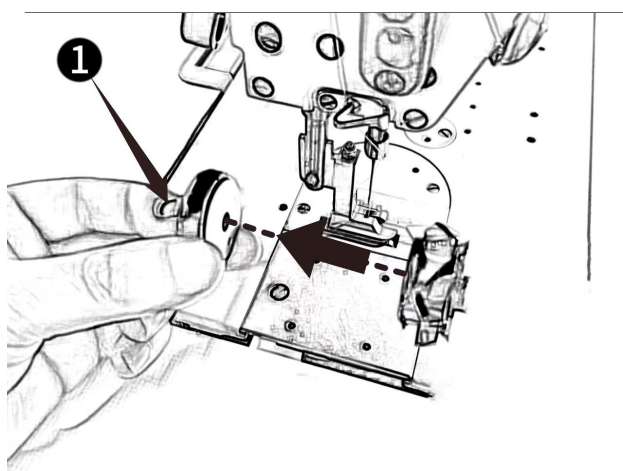

- 1) 转动手轮，把机针上上到最高的位置。
Turn the hand-wheel by hand to raise the needle to its highest position.
- 2) 扳起梭壳的抓片①，取下梭壳。
Raise bobbin case latch ① and remove the bobbin case.

6.03 底线的卷线方法 Winding the bobbin thread

	注意 为了防止突然的起动造成人身事故，请关掉电源，确认马达完全停止后进行操作。 To protect against possible personal injury due to abrupt start of the machine, be sure to start the following work after turning the power off and ascertaining that the motor is at rest.
---	--

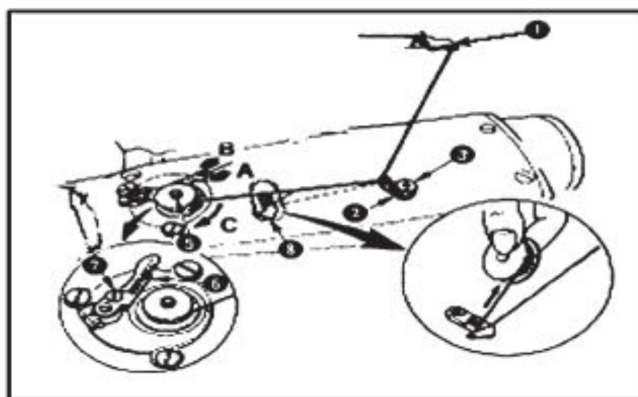

- 1) 把梭心插到绕线轴上 ⑤ 上
Insert the bobbin deep into the bobbin winder spindle ⑤ until it will go no further
- 2) 把线架右侧的卷线拉出的线按图中从 ① 开始的顺序穿线，然后把线端在梭心上卷绕线圈
Pass the bobbin thread pulled out from the spool rested on the right side of the thread stand following the order from ① as shown in the figure on the left. Then, wind the end of the bobbin thread on the bobbin several times.
- 3) 向 A 方向按压绕线拨杆 ⑥，让缝纫机转动。梭心向 C 方向转动，线被绕到梭心上。绕完之后绕线轴 5 自动停止。
Press the bobbin winder adjusting plate ⑥ in the direction A and start the sewing machine. The bobbin rotates in the direction of C and the bobbin thread is wound up. The bobbin winder spindle 5 will automatically stop as soon as the winding is finished.
- 4) 取下梭心，用切线保持板 ⑧ 切线。
Remove the bobbin and cut the bobbin thread, with the thread cut retainer ⑧.
- 5) 调整底线卷绕量时，拧松固定螺钉 ⑦，向 A 或 B 方向移动绕线调节板 ⑥，然后拧紧固定螺钉 ⑦。
To adjust the winding amount of the bobbin thread, loosen setscrew ⑦ and move bobbin winder adjusting plate ⑥ to the direction of A or B. Then, tighten screw ⑦
A 方向：变少
To the direction A: The amount is decreased.
B 方向：变多
To the direction b: The amount is increased.

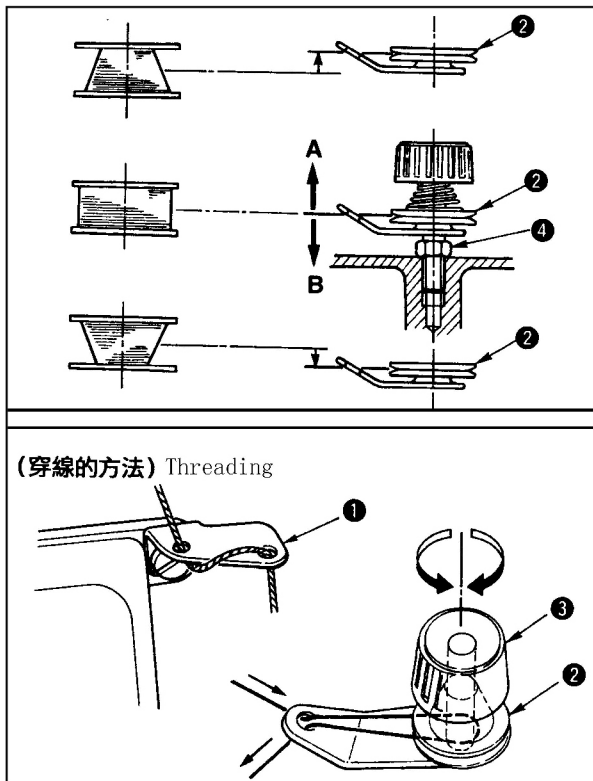

6) 如果线不能平坦地卷线时, 请拧松螺母④, 转动卷线线张力器, 调整线张力器②的高度。

- 梭心的中心和线张力盘的中心高度相同时为标准

- 下面绕得多时, 向左图的 A 方向移动线张力盘②, 上面绕得多时, 向左图的 B 方向移动线张力盘的位置。

调整后, 拧紧固定螺母④。

In case that the bobbin thread is not wound evenly on the bobbin, loosen the nut ④ and turn the bobbin thread tension to adjust the height of the thread tension disk ②.

- It is the standard that the center of the bobbin is as high as the center of the thread tension disk.

- Move the position of the thread tension disk ② to the direction A as shown in the figure on the left when the winding amount of the bobbin thread on the lower part of the bobbin is excessive and to the direction B as shown in the figure on the left when the winding amount of the bobbin thread on the upper part of the bobbin is excessive.

After the adjustment, tighten the nut ④

7) 调整底线张力时, 转动线张力螺母③, 进行调整。

Turn the thread tension nut ③ to adjust the tension of the bobbin thread winder

6.04 梭心的放入方法

Placing the bobbin case and the bobbin



注意

为了防止突然的起动造成人身事故，请关掉电源，确认马达完全停止后进行操作。
To protect against possible personal injury due to abrupt start of the machine, be sure to start the following work after turning the power off and ascertaining that the motor is at rest.

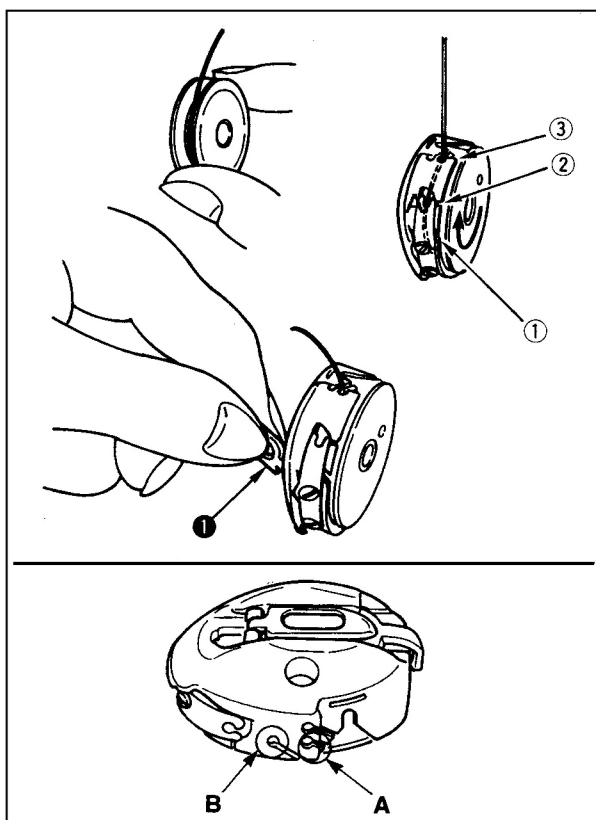

- 1) 转动手轮，把机针升到最高的位置。
- 2) 如图所示的那样，把梭心的线端拉出 5cm 左右，然后放入梭壳里。
- 3) 将线按槽上的号码顺序穿线，从线口拉出线。一拉底线梭心就会向箭头方向转动。
- 4) 如图所示那样，掀起梭壳的抓片 ❶。
- 5) 这时，从下护罩把手伸进，深深地插进内旋梭轴
- 6) 确实关好梭壳的抓片

■梭壳线孔的使用方法

- 1) A 孔主要在缝制 2 点曲折缝、扇形荷叶边曲折缝以外时使用
- 2) B 孔主要在缝制 2 点曲折缝、扇形荷叶边曲折缝时使用

- 1) Turn the hand-wheel by hand to raise the needle to its highest position.
- 2) Take a bobbin by your right hand with the thread drawn out about 5 cm from the thread end of the bobbin and place it into the bobbin case as illustrated.
- 3) Thread the bobbin case in the order of the numbers and pull it out through the thread path as illustrated. Shown by arrow when bobbin thread is drawn.
- 4) Raise bobbin case latch ❶ and hold it between your two fingers as shown in the figure on the left.
- 5) Insert the bobbin case into the sewing hook shaft as far as it will go by putting your hand from the under corer of the inner hook.(Click sounds)
- 6) Release the bobbin case latch to let it steadily rest in the closing position.

■ How to use the bobbin case thread hole

- 1) Use hole A mainly for zigzag stitches other than standard zigzag stitch and scallop zigzag stitch.
- 2) Use hole B mainly for standard zigzag stitch and scallop zigzag stitch

7 缝制 SEWING

7.01 线张力的调整方法 Adjusting the thread tension

	危险	发生断线后，有时线被卷到挑线杆上。此时，请打开挑线杆护罩的线。此时请注意不要割到手。
In case of thread-breakage. It may occur that the thread tangles around the take-up lever. In this case, remove the thread tangling around the thread take-up cover. At this time, be careful not to cut fingers with the knife.		

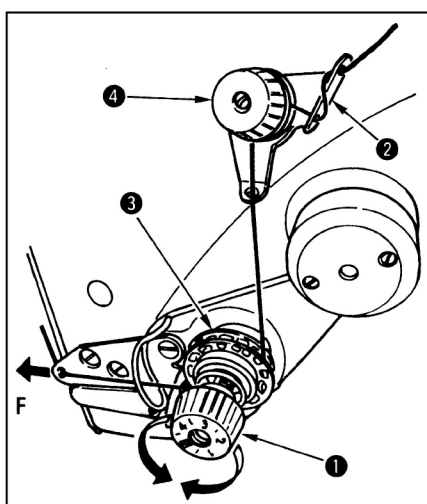

(1) 上线张力的调整

- 1) 上线张力螺母①来调整
向右转动变强。
向左转动变弱。

Adjusting the needle thread tension

- 1) Adjust the needle thread tension using the tension nut ①.
Turning the tension nut clockwise increases the needle thread tension, or counterclockwise decreases it.

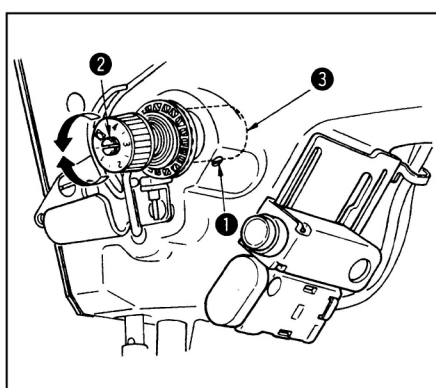

(2) 挑线弹簧的调整

- 1) 变更挑线弹簧的强度时，拧紧线张力杆的紧固螺丝①，把螺丝刀插到线张力杆②的槽里进行调整。
向右转动变强。
向左转动变弱。
- 2) 变更挑线弹簧挑线量时，拧松线张力杆紧固转动线张力杆座③进行调整。
挑线量范围 6~10mm

Adjusting the thread take-up spring

- 1) To change the tension of the thread take-up spring, firmly tighten the screw ① which fastens the tension post ② to the machine arm and insert the blade of a screwdriver into the slot in the tension post to adjust the tension of the thread take-up spring.
Turn it clockwise to increase.
Turn it counterclockwise to decrease.
- 2) To change the amount of thread taken by the thread take-up spring, loosen the clamping screw ① of the tension post socket and turn the tension post socket ③. Adjustable range of the amount of thread taken by the thread take-up spring: 6 to 10 mm.

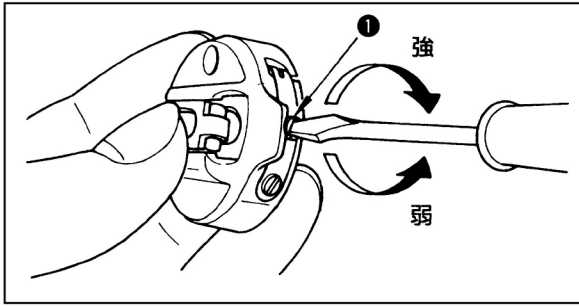

(3) 底线张力的调整

- 1) 底线张力，转动梭壳的线张力螺丝①来进行调整。
向右转动变强。
向左转动变弱。

Adjusting the bobbin thread tension

- 1) The tension of the bobbin thread is adjusted by turning the tension adjusting screw ①.
Turn it clockwise to increase.
Turn it counterclockwise to decrease.

7.02 压脚压力的调整

Adjusting the pressure of the presser foot



为了防止突然的起动造成人身事故，请关掉电源，确认马达完全停止后进行操作。
To protect against possible personal injury due to abrupt start of the machine, be sure to start the following work after turning the power off and ascertaining that the motor is at rest.

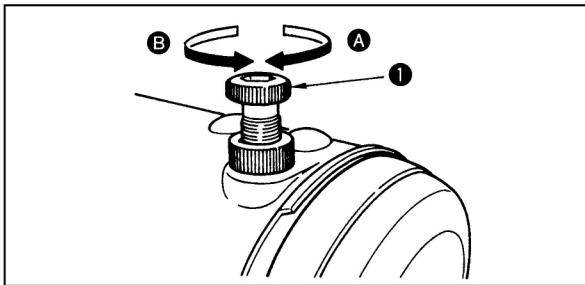

- 1) 向右Ⓐ方向转动压脚调节螺丝①变强。
- 2) 向左Ⓑ方向转动压脚压力变弱。

- 1) Turn the presser spring regulator ① clockwise Ⓐ to increase the pressure given by the presser foot.
- 2) Turn the presser spring regulator counterclockwise Ⓑ to decrease it.

7.03 拨杆手动倒缝

One-touch type reverse feed stitching mechanism

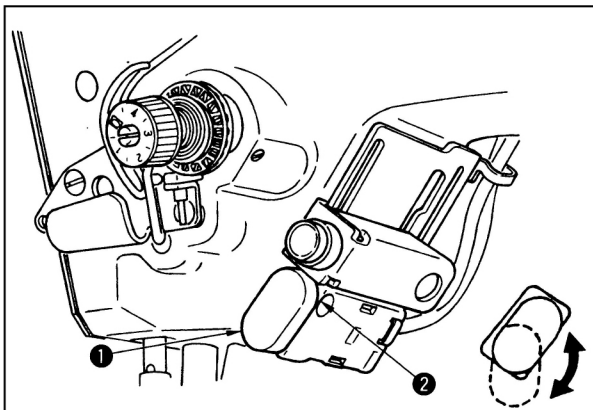

(1) 使用方法

- 1) 如果按了倒送开关①，缝纫机立即变为倒送，进行倒缝。
- 2) 按下的时间可以进行倒缝。
- 3) 手离开后，立即变为正送。
- 4) 让倒送开关①转动，可以在2个位置使用。

How to use the reverse feed switch lever

- 1) Press reverse feed switch ①, and the sewing machine will immediately run in the reverse direction to perform the reverse feed stitching.
- 2) Reverse stitching is performed as long as you keep the lever held pressed down.
- 3) Release the switch lever, and the machine will immediately run in the normal direction.
- 4) Reverse feed switch ① can be used in two positions by turning it.

(2) 开关的高度

Height of the switch



注意

为了防止突然的起动机造成人身事故，请关掉电源，确认马达完全停止后进行操作。
To protect against possible personal injury due to abrupt start of the machine, be sure to start the following work after turning the power off and ascertaining that the motor is at rest.

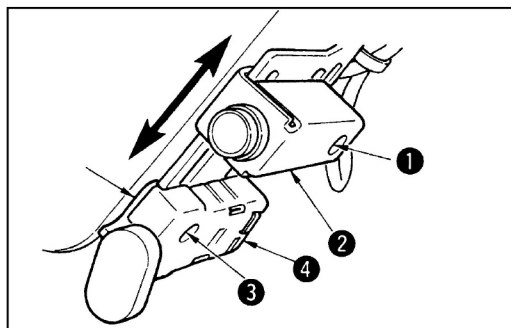

- 1) 请拧松固定螺钉①，上下调整对称 SW②。
- 2) 拧松固定螺钉③，上下移动倒送开关④，调整高度。

倒送开关④和对称 SW②的位置可以反过来设定。

- 1) Loosen setscrew① and adjust up or down mirror switch②.
- 2) Loosen setscrew③ and move up or down reverse feed switch④ to adjust the height.

The position of reverse feed switch④ and mirror switch② can be reversed.

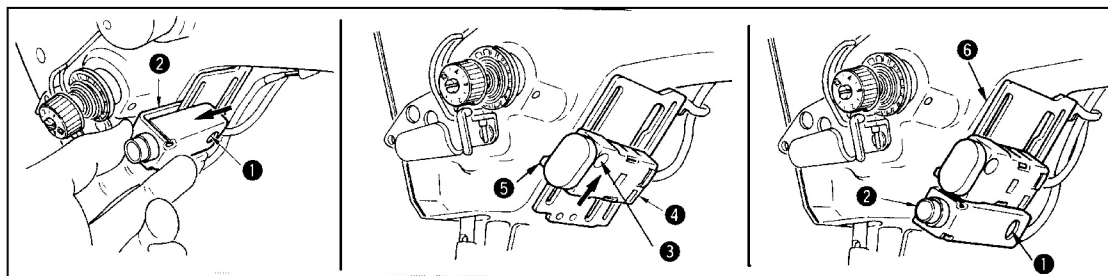

- 3) 请拧松固定螺钉①，卸下对称 SW②。
- 4) 稍稍拧松固定螺钉③，向上移动倒送开关④和道向器⑤，然后用道向器⑤和固定螺钉③进行固定。
- 5) 把对称 SW②放到安装座⑥上，然后用固定螺钉①进行固定。（放入对称 SW②，夹住安装座⑥。

注：请自由得调节各开关的高度。

- 3) Loosen setscrew① and remove mirror SW②.
- 4) Slightly loosen setscrew③, move upward reverse feed switch④ and guide⑤, and fix the switch with guide⑤ and setscrew③.
- 5) Put mirror SW② in installing base⑥ and fix it with setscrew①.

(Put mirror SW② in installing base⑥ so that the installing base⑥ is inserted in the mirror SW②.)

Note: Freely adjust the height of the respective switches.

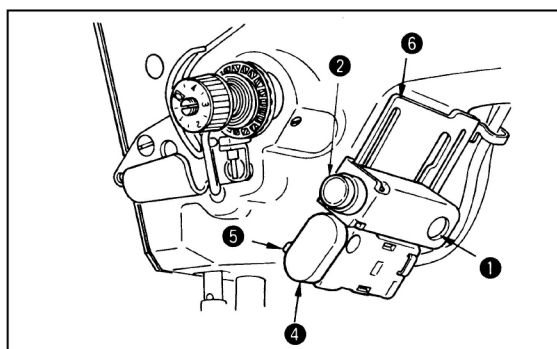

倒送开关④和对称 SW②的位置可以反过来设定。

A. 带辅助挑线杆规格变更开关位置时，请参照 3)~5) 项的内容。

注：请自由得调节各开关的高度。

The position of reverse feed switch④ and mirror switch② can be reversed.

When changing the position of the switch in case of "A. In case of the machine with the auxiliary thread take-up lever", refer to the items 3) through 5).

Note: Freely adjust the height of the respective switches.

7.04 关于手持开关 Hand switch

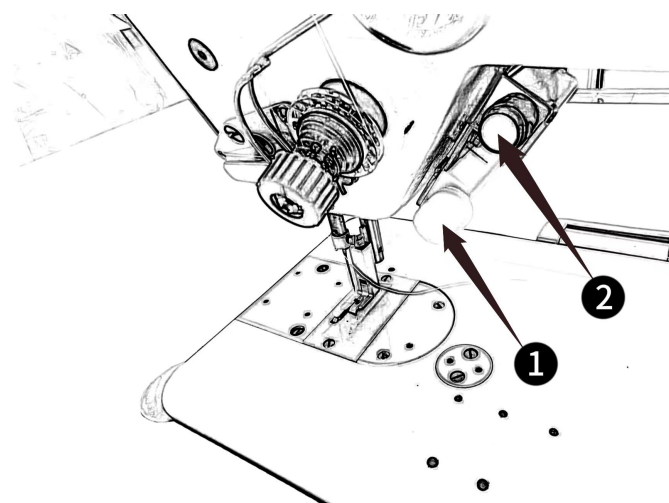

- 1) 倒送开关①
按了倒送开关①之后，进行倒送。手放开之后，变为正送。
 - 2) 对称缝制开关②
选择了扇形荷叶边、随机图案、连续缝制时，变为对称缝制开关。
- 1) Reverse feed switch①
Press reverse feed switch ① and reverse feed is performed. When it is released, normal feed is performed.
 - 2) Mirror switch②
When scallop, custom pattern or continuous stitching is selected, the switch becomes a mirror switch.

所谓对称翻转功能就是在缝制中途停止时，按对称翻转开关之后，缝制反图案的功能。
有关对称翻转开关的高度调整，请参照 P21。

Mirror inversion means the function that the reverse pattern sewing is performed after pressing the mirror inversion switch during temporary stop of sewing.

For the adjustment of the height, see p21.

■缝制方法（例：贝壳装饰缝）

- 1) 缝制中，在让缝纫机对称反转缝制的位置停止缝纫机。
- 2) 按对称反转开关②。对称反转开关打开之后，LED 亮灯。
(开关只在停止中起作用。缝纫机运转中不起作用。)
- 3) 用缝纫机进行对称反转缝制。
- 4) 切线，或再次按对称翻转开关，结束翻转缝制。

■Sewing procedure (Example: scallop)

- 1) Stop the sewing machine at the position you desire to perform mirror inversion during sewing.
- 2) Press the mirror inversion switch. When the mirror inversion switch is received, LED lights up.(The switch can receive only when the sewing machine stops and dose not receive when the sewing machine is running.)
- 3) Perform mirror inversion sewing with the sewing machine.
- 4) Perform thread trimming or press again the mirror inversion switch to complete the inversion sewing.

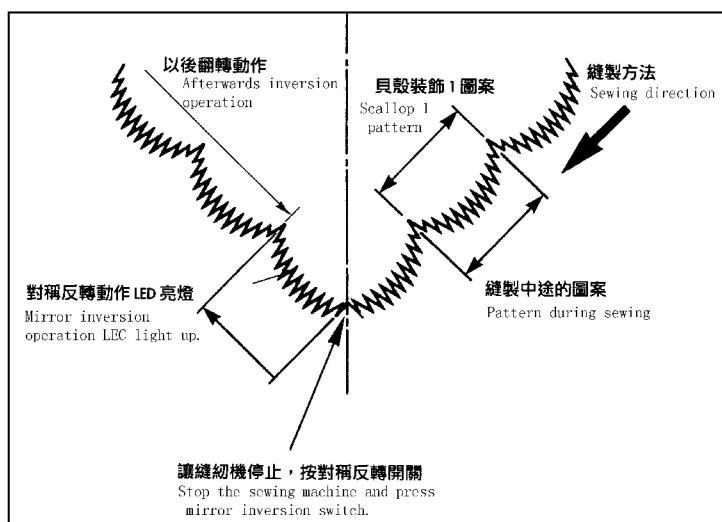

8 标准调整 STANDARD ADJUSTMENT

8.01 旋梭油量的调整 Adjusting the amount of oil in the hook



为了防止意外的起动造成人身事故，请关掉电源后进行操作。
Turn OFF the power before starting the work so as to prevent accidents caused by abrupt start of the sewing machine.

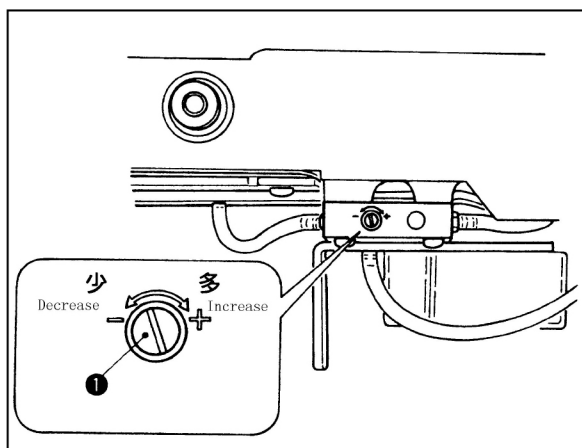

旋梭油量用旋梭油量调节螺丝①来调节

(1) 调节方法

拧紧（向右转动）旋梭油量调节螺丝①后，旋梭油量变多，拧松（向左转动）旋梭油量变少。

Adjustment the amount of oil in the hook
Adjustment of the amount of oil in the hook is performed with oil amount adjustment screw ①.

(1) Adjustment procedure

Tighten (turn clockwise) oil amount adjustment screw ① to increase the amount of oil in the hook , or loosen (turn counterclockwise) to decrease it .



1. 调整旋梭油量时，请先稍稍多量加油，然后减少油量进行调整。
2. 旋梭油量出货时是按照最高转速进行调整的，如果顾客经常使用低速运转，有可能因旋梭油量不足而发生鼓掌，因此经常以低速运转时，调整旋梭油量。
3. 在旋梭油量调整螺丝 1 全部拧紧的状态下使用的话，因为机油不能回流到机油槽里，所以可能发生从旋梭轴漏油的故障，请不要把螺丝全部拧紧。另外，如果不把旋梭油芯堵塞，因此请更换旋梭轴油芯。

1. When adjusting the amount of oil in the hook, perform the adjustment in a way of reducing the oil amount after somewhat increasing it.
2. The amount of oil in the hook has been adjusted at the max. number of revolution at the time of delivery. When you always use the sewing machine at low speed, there is a possibility that trouble occurs due to the lack of amount of oil in the hook. When the sewing machine is used always at low speed, perform the adjustment of the amount of oil in the hook.
3. There is a possibility of causing oil leakage from the hook shaft section since oil does not return to the oil tank when oil amount adjustment screw ① is used in fully-tightened state. Do not use the screw in fully-tightened state. In addition, when the amount of oil in the hook is not obtained unless oil amount adjustment screw ① is near in fully-tightened state, it is considered that hook shaft oil wick is clogged or the like. Replace the hook shaft oil wick.

8.02 机头面部加油量的调整

Adjusting the amount of lubricating to face plate section



为了防止意外的起动造成人身事故，请关掉电源后进行操作。

Turn OFF the power before starting the work so as to prevent accidents caused by abrupt start of the sewing machine.

工厂出货时已进行了调整，因此机头面部加油量不需要调整。（机头面部加油槽油量调整螺丝②由于不需要调整，因此用固定栓①遮隐着。如果错误的调整（不是旋梭油量调整）的话，请按照下列说明重新调整。

It is not necessary to adjust the amount of lubricating to face plate section since it has been factory-adjusted at the time of deliver .(Oil amount adjustment screw ② in the face plate section lubricating tank is hidden with stop plug ① since it is not necessary to be adjusted.)

When the adjustment is performed by mistake (mistaken as the adjustment of oil amount in the hook), re-adjust as shown below.

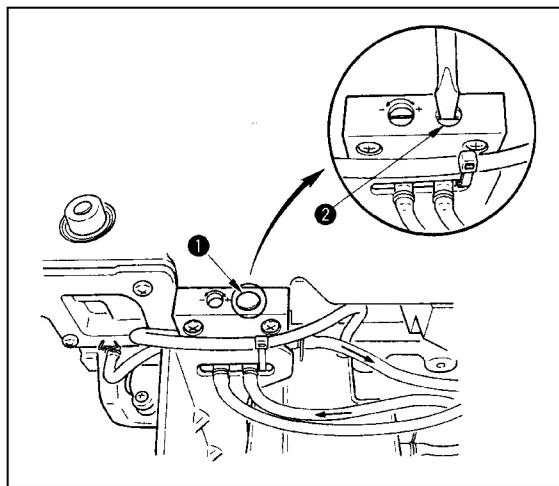

- 1) 卸下固定栓①，轻松地拧紧调整螺丝②后，请从固定位置反转 0.6 圈。
- 2) 如果正常，则可以确认到机油的流动。（图的箭头方向）如果不流动时，请一定重新调整。（不重新调整会磨损机头面部机构）

- 1) Remove stop plug ① , and when lightly tightening the adjustment screw ② .return the screw by approximately 0.6 turn form the stop position.
- 2) In case of the normal state , the flow of oil can be confirmed(direction of the arrow in the illustration).In case the flow is stopped , be sure to adjust . (Worn-out of the mechanism of face plate section will be caused .)

8.03 压脚杆高度的调整

Adjusting the height of the presser bar

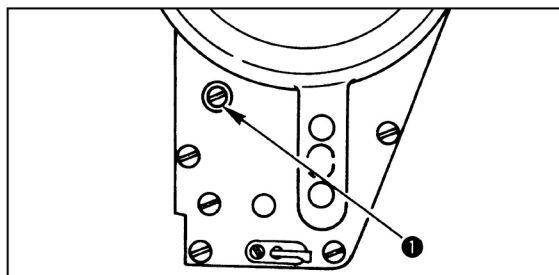

- 1) 想要变更压脚杆的高度或压脚的角度时，拧松压脚套管固定螺丝①进行调整。
- 2) 调整后，拧紧固定螺丝。

- 1) To change the height of the presser bar or the inclination of the presser foot. Loosen the presser bar connection screw ① and perform the adjustment properly .
- 2) After the adjustment securely tighten the screw .



注意

为了防止突然的起动造成人身事故，请关掉电源，确认马达完全停止后进行操作。
To protect against possible personal injury due to abrupt start of the machine, be sure to start the following work after turning the power off and ascertaining that the motor is at rest.

8.04 压脚微量浮起的调整

Adjusting the micro-lifting mechanism of the presser foot

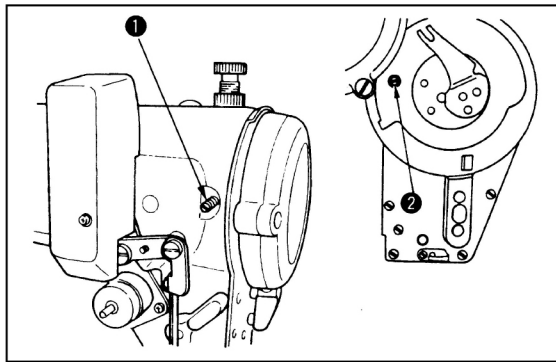

有的缝制料请把压脚稍稍浮起进行缝制。其调整方法如下：

- 1) 拧松压脚浮起固定螺丝 1。
- 2) 向左右方向转动压脚浮起螺丝 2，调整到需要量后用固定螺丝 1 拧紧固定。

Some type of material needs to be sewn with the presser foot slightly lifted. In this case, perform this adjustment following the procedure described below.

- 1) Loosen the setscrew ❶ in the presser foot micro-lifter .

- 2) Turn the presser foot micro-lifting screw ❷ clockwise through the hole in the face plate until the presser foot is raised as desired. Then, tighten the screw ❶ .



不使用时，请把压脚浮起螺丝❷全部转回来。浮起量大约是 1 张纸的厚度。

If you do not use the micro-lifting mechanism of the presser foot, fully return the presser foot micro-lifting screw❷ to its home position.

The standard of lifting amount of the presser foot is as thick as a sheet of paper

8.05 送布牙的高度、倾斜

Height and inclination of the feed dog



注意

为了防止突然的起动造成人身事故，请关掉电源，确认马达完全停止后进行操作。
To protect against possible personal injury due to abrupt start of the machine, be sure to start the following work after turning the power off and ascertaining that the motor is at rest.

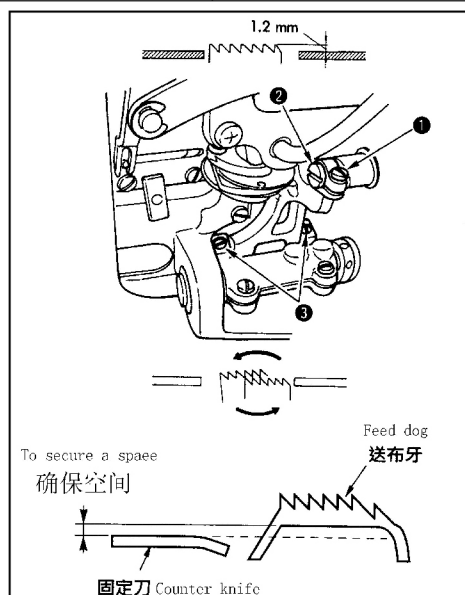

- 1) 如图所示拧松上下送布环轴固定螺丝❶，用螺丝刀转动上下送布轴❷来调整送布牙高度。
 - 2) 送布牙的高度标准为 1.2mm。
 - 3) 调整送布牙倾斜角度时，如图所示拧松送布台轴固定螺丝❸，用螺丝刀穿过机台上的孔，转动送布台轴进行调整。
 - 4) 切线规格几种时，调整了送布（高度，同步时间等变更）后或使用市场出售的送布牙后，有时固定刀和送布牙之间空间没有。此时需要垫上送布台垫片和针板下面用针板垫以确保空间。
- 送布牙的标准倾斜是，送布牙从针板出来时，呈水平状态。

- 1) To adjust the height of the feed dog, loosen the screw ❶ and turn the feed driving link pin ❷ using a screwdriver.
- 2) The standard height of the feed dog is 1.2 mm .
- 3) To adjust the inclination of the feed dog , loosen the two screws ❸ and turn the eccentric shaft inserting screwdriver through the adjustment hole in the machine bed .
- 4) For the machine with a thread trimmer , there can be no space between the counter knife and the underside of the feed dog when adjusting the feed mechanism (change in height and timing) or using a commercially-available feed dog . In this case , place a feed bar spacer under the feed mechanism and a throat plate spacer under the throat plate so as to secure a space between the counter knife and the underside of the dog .

The standard inclination of the feed dog is obtained by adjusting the feed dog so that it becomes horizontal when it rises above the top surface of the throat plate.

8.06 旋梭的安装, 拆卸 Attaching/removing the hook



注意

为了防止突然的起动造成人身事故, 请关掉电源, 确认马达完全停止后进行操作。
To protect against possible personal injury due to abrupt start of the machine, be sure to start the following work after turning the power off and ascertaining that the motor is at rest.

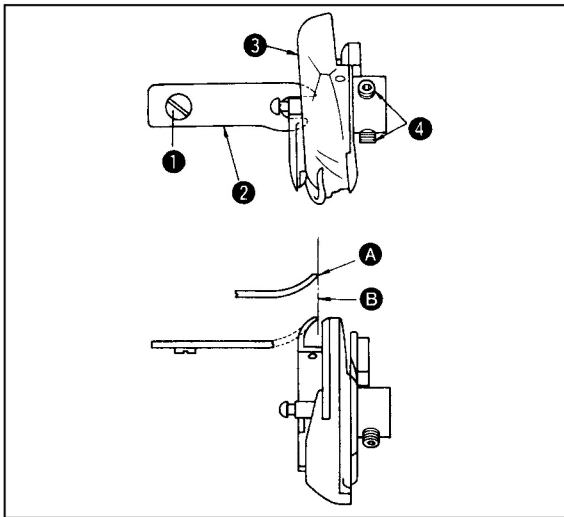

更换旋梭时, 请按照一下顺序进行。

- 1) 转动手轮, 把机针上升到最高位置。
- 2) 卸下机针、压脚、针板、送布牙、梭壳。
- 3) 卸下内旋梭固定螺丝 ❶, 取下内旋梭固定部件 ❷。
- 4) 拧松旋梭 ❸ 的固定螺丝 ❹。

安装旋梭时, 按此相反的顺序进行。此时, 内旋梭固定部件前端 A 基本与图的 B 线一致。但是, 前短不能向右侧凸 图的 B 线外。

When you replace the sewing hook , remove it in the following procedures ;

- 1) Turn the hand wheel until the needle reaches to

its highest position .

- 2) Remove the needle, presser foot, throat plate, feed dog and bobbin case from the machine.
- 3) Remove the setscrew ❶ and take out the bobbin case positioning finger ❷ .
- 4) Loosen the two screws ❹ and remove the sewing hook ❸ .

Reverse the above procedures when inserting the sewing hook. At this time , make sure that top end A of the bobbin case positioning finger is aligned with line B. as shown in the figure on the left . Never let A protrude form line B.

8.07 针高度（预校验）

Needle height (preliminary adjustment)



注意

为了防止突然的起动造成人身事故，请关掉电源，确认马达完全停止后进行操作。
To protect against possible personal injury due to abrupt start of the machine, be sure to start the following work after turning the power off and ascertaining that the motor is at rest.

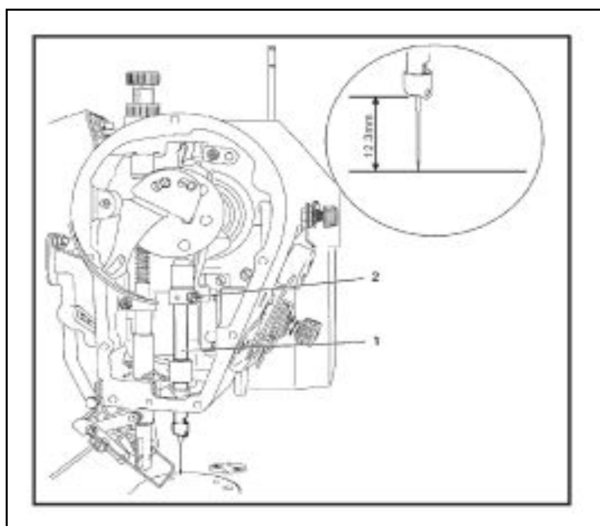

在针杆下死点，针杆应该停在针板上方 12.3mm 的位置。

- 1) 摆动宽度设为 0，机针位置设为中间。
- 2) 卸下压脚，如图所示拧松固定螺丝②，在不转动的情况下移动针杆①。

When the needle bar is at b.d.c (bottom dead centre), the needle bar should be 12.3 mm above the needle plate.

- 1) Set the zigzag width "0". Bring the needle to the center of the zigzag stroke.
- 2) Remove the presser foot, to which the throat plate is to be attached, of the bed. Loosen setscrew ②. Without twisting it, adjust needle bar ① (screw ②) in accordance with the

8.08 针杆提升行程、旋梭距离和旋梭定位钩

Needle rise, hook clearance and bobbin case position stop



注意

为了防止突然的起动造成人身事故，请关掉电源，确认马达完全停止后进行操作。
To protect against possible personal injury due to abrupt start of the machine, be sure to start the following work after turning the power off and ascertaining that the motor is at rest.

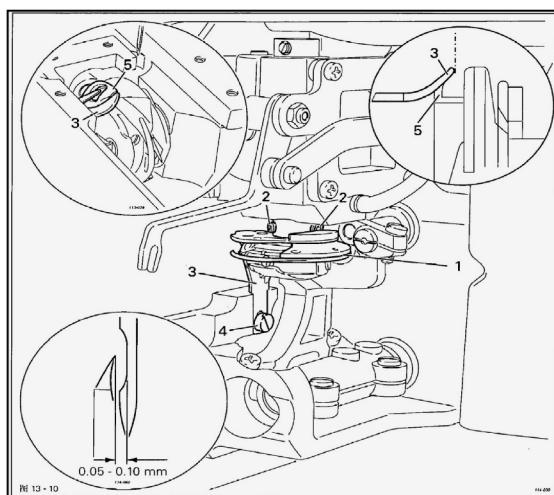

- 1) 在锁缝宽度和针距设在“0”时，针杆位置在下死点后 3.4mm 时，旋梭尖应该停在针的中心，并且针杆和旋梭尖之间应该有一个 0.05~0.10mm 的距离。
- 2) 旋梭定位钩③的前棱边与止挡⑤的棱边处在同一高度上。

When the zigzag stitch and the stitch position set at "0", when the needle bar is positioned at 3.4 mm after b.d.c, the hook point should be contacted to the needle and the needle to hook point clearance should be 0.05 – 0.10 mm.

The front edge of the bobbin case position stop 3 should be level with the edge of holder 5.



发生断线后，有时线被咬进旋梭。请解开被咬进的线，然后再进行缝制。
When thread breakage has occurred, there is a case where thread is caught in the hook.

Be sure to perform sewing after removing the thread caught in the hook.

8.09 机针停止位置的调整 Adjusting the stop position of the needle

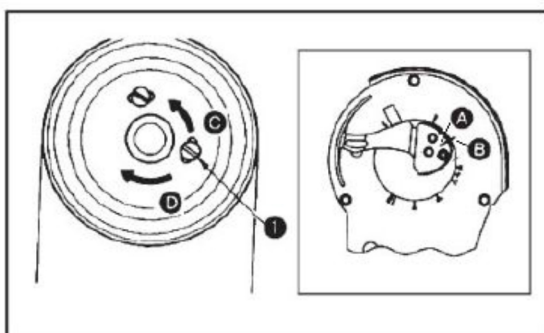

拧松螺丝 1，请不要运转。另外，只把它拧松，不要卸下来。
Do not operate the sewing machine with screw 1 loosened. Loosen the screw only, and do not removed it.

(1) 切线后的停止位置

- 1) 标准的机针停止位置是挑线盘的刻点 A 和面板上的刻点 B 对齐的位置。
- 2) 让机针上停止，拧松螺丝 ①，在长孔的范围内进行调整。
 - ① 向 C 的方向移动，机针停止提前。
 - ② 向 D 的方向移动，机针推迟。

(1) Stop position of the needle after thread trimming

- 1) The needle stops at the standard stop position when marker dot A engraved on the hand wheel cover is aligned with white marker dot B engraved on the hand wheel .
- 2) Stop the needle at the highest position of its stroke , loosen screw ① , and adjust the stop position of the needle by moving screw ① within the slot .
 - ① Move the screw in the direction C to advance the timing to make the needle stop .
 - ② Move the screw in the direction D to retard the timing to make the needle stop .

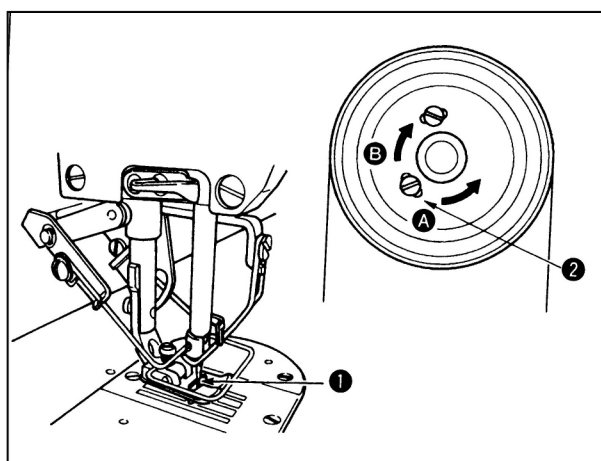

(2) 拧松螺丝 ② 在长孔范围内进行调节，向前踩踏板到中立时机针正好在下停止位置，同样让机针 ① 下停止之后进行调整。向 A 的方向移动机针停止提前，向 B 方向移动则推迟。

When you return the pedal to its neutral position after having depressed the front part of it , the needle stops at the lowest stop position . As in the case of the adjustment of the highest stop position of the needle , stop the screw ① in the lowest position of its stroke , loosen the

screw ② , and adjust the lowest stop position of the needle by moving the screw ② within the slot. Move the screw in the direction A to advance the timing to make the needle stop or in the direction B to retard it .

8.10 切线的调整 Adjusting the thread trimmer



注意

为了防止突然的起动造成人身事故，请关掉电源，确认马达完全停止后进行操作。
To protect against possible personal injury due to abrupt start of the machine, be sure to start the following work after turning the power off and ascertaining that the motor is at rest.

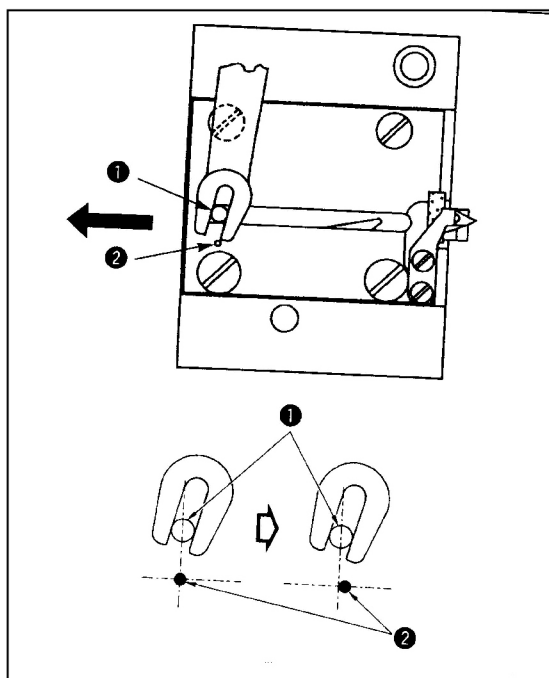

(1) 移动刀的初期位置

移动刀的初期位置如图所示，让移动刀销钉①与刻点②一致。

Initial position of the moving knife

When the moving knife is in its initial position, the moving knife pin ① should be aligned with the engraved marker dot ② as shown in the figure on the left.

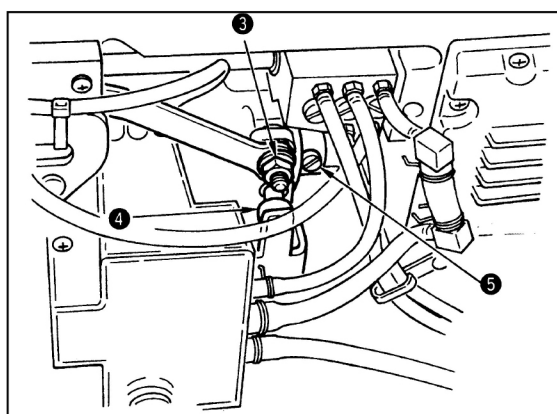

初期位置不正确时

拧松螺母③，左右移动，调整①、②。

在适合的位置拧紧螺母③。

If the initial position of the moving knife is not correct

Loosen the nut ③, and move the moving knife to the right or left until the pin ① meets the marker dot ②. Then, tighten the nut ③.

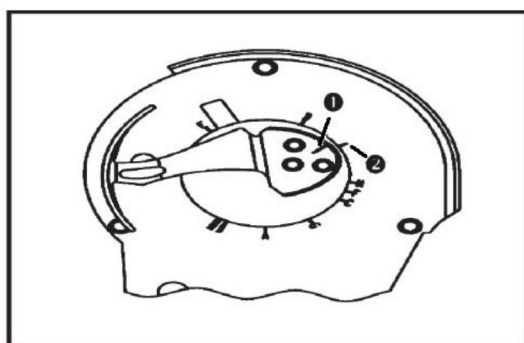

(2) 切线同步的调整

把凸块④嵌入凸轮槽的状态，静静地逆转身轮时，当挑线盘的刻点①和面板的刻点②后侧2mm对准的位置，手轮不能转动。调整切线凸轮，凸块嵌入凸轮槽的状态下，慢慢向与下轴转动相反的方向转，在停止的位置把2个螺丝⑤固定起来。

(2) Adjusting the thread trimming timing

Put roller ④ in the cam groove. Now, gradually turn the hand wheel in the reverse direction.

Put roller ④ in the cam groove. Now, gradually turn the hand wheel will go no further when marker dot ① engraved on the hand wheel cover is aligned with red marker dot ② engraved on the hand wheel.

To adjust the thread trimmer cam, align the red marker dot on the hand wheel cover with the red marker dot on the hand wheel, put the roller in the groove of the thread trimming cam, and gradually turn the hand wheel in the direction opposite to the direction of rotation of the hook driving shaft until it will go to further. Now, tighten two screws ⑤.

8.11 上线挑线装置的调整

Adjusting the needle thread feeding device

	<p>注意</p> <p>为了防止突然的起动造成人身事故，请关掉电源，确认马达完全停止后进行操作。 To protect against possible personal injury due to abrupt start of the machine, be sure to start the following work after turning the power off and ascertaining that the motor is at rest.</p>
---	--

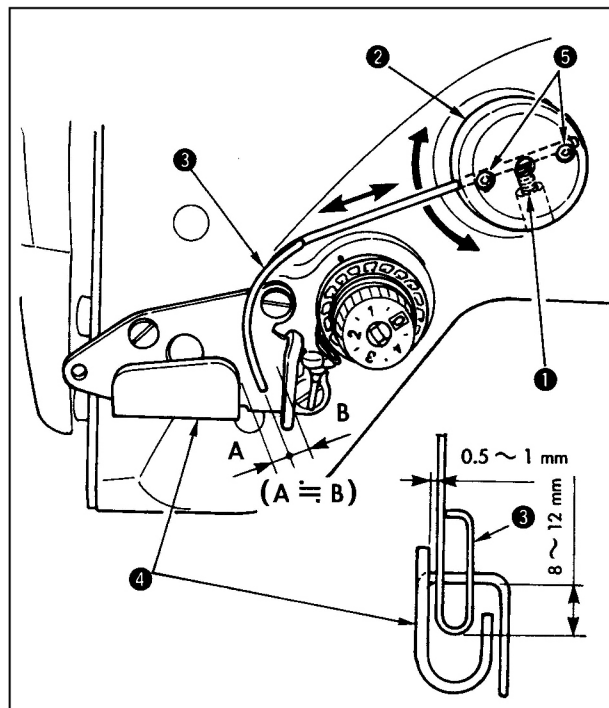

■ 挑线杆的标准位置

- 1) 拧松固定螺丝 ①。
- 2) 转动挑线杆安装台 ②，让挑线弹簧 ③ 的前端于挑线道向器 A4 的道向部距离为 C (8~12mm)，然后拧紧固定螺丝 ①。

此时，挑线杆和挑线道向器 A 的表面相距 0.5~1 mm。

注意 At this time, leave a space of 0.5 to 1mm between the feeding wire and the Top surface of the thread the feeding wire and the top surface of the thread take-up thread guide A.

- 3) 进行微调，让挑线杆的前端应基本在挑线道向器 A 的中心位置 (A=B)，然后拧紧固定螺丝 ⑤。

■ 想加大上挑线量时

请拧松固定螺丝 ⑤，调整为 A>B。

拧松固定螺丝 ①，向上（较小地设定 C 的值）调整挑线杆安装座 ② 整体，可以大量调整挑出量。

■ Standard position of the feeding wire

- 1) Loosen screw ①.
- 2) Turn the feeding wire together with feeding wire installing base ②, adjust the installing position of the feeding wire so that a distance of C (8 to 12mm) is provided between the top end of feeding wire ③ and the guide portion of thread take-up thread guide A ④, and tighten screw ①.
- 3) Finely adjust with setscrews ⑤ so that the top end of the feeding wire is placed approximately in the center (A≈B) of the thread take-up thread guide A.

When needle thread feeding amount is desired to be increased:

- Loosen setscrew ❶ and adjust the relation between A and B to A>B .
- Loosen setscrew ❶ and when the whole feeding wire installing base ❷ is adjusted to the upward direction (decrease the value , C) , the feeding amount can be increased .

9 维修和保养 MAINTENANCE AND MAINTENANCE

 危险	<p>为了防止突然的起动造成人身事故，请关掉电源，确认马达完全停止后进行操作。 To protect against possible personal injury due to abrupt start of the machine, be sure to start the following work after turning the power off and ascertaining that the motor is at rest.</p>
---	---

9.01 保养间隔 Maintenance intervals

清洁.....	每天一次，长期运行时，多次
油量检查.....	每天一次，在工作前
Cleaning.....	daily, several times if in continuous use
Checking the oil level.....	daily, before operation



上述的保养间隔是根据每天一班作业的平均机器运行时间设定的。在机器运行时间提高的情况下，建议缩短保养间隔。

**During all cleaning work the machine must be disconnected from the power supply by switching off the main switch or pulling out the plug!
 Danger of injury if the machine is started accidentally!**

9.02 机器的清洁 Cleaning the machine

本机器所要求的清洁周期取决于下列因素：

The cleaning cycle required for the machine depends on following factors:

- 单班或多班运行
- 缝纫尘的掉落情况
- Single or several shift operation
- Amount of dust resulting from the work-piece

因此，最佳的清洁规定只能按具体情况设定。

It is therefore only possible to stipulate the best possible cleaning instructions for each individual case.



在做清洁工作时，必须通过总开关或通过拉下电源插头将机器与电源分开！
 无意地引起机器起动能有受伤的危险！

To avoid breakdowns, the following cleaning work is recommended for single shift operation:

为了防止出现运行故障，推荐在单班作业时做好下列的清洁工作：

To avoid breakdowns the following cleaning work is recommended for single shift operation:



- 对线梭匣和机针区每天进行多次清洁。
- 最少每天一次对整机进行全面清洁。
- Clean hook compartment and needle area of sewing head several times daily.
- Clean the entire machine at least once a week.

9.03 机器上油 Oiling the machine

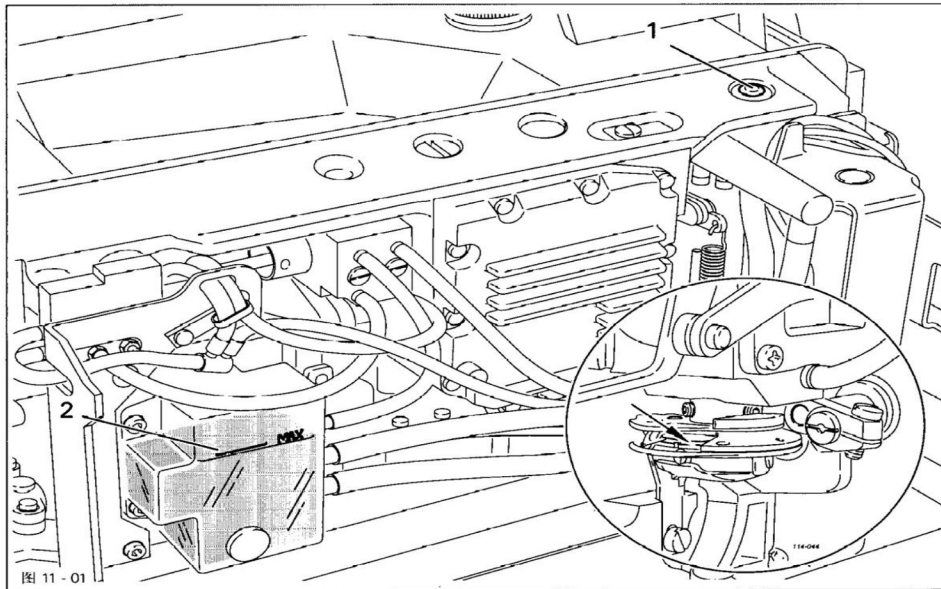

关闭机器！

无意地引起机器起动有受伤的危险！

Switch off the machine!

Danger of injury if the machine is started accidentally!

只允许使用在 40 ° C 时平均粘度为 10.0mm²/s 和在 15° C 时比重为 0.847g/cm³ 的润滑油！

Only use oil with a viscosity of 10.0 mm²/s at 40°C and a density of 0.847 g/cm³ at 15°C.



- 1) 向后翻起。

Tilt the machine back.

- 2) 取下封堵①，并通过注油口将油注满至标记②。

Remove plug ① and pour oil into the hole until it reaches marking ②.

- 3) 在首次试车调试和在长期停车后重新开车，附加地在旋梭道上加几滴油，见局部放大中的箭头。

Before commissioning the machine and after long down periods, pour a few extra drops of oil into the hook race, see arrow in enlarged illustration.



必须用双手将机头放回垂直位置！

有在机头和抬板之间被挤伤的危险！

Use both hands to set the sewing head upright!

Danger of crushing between the sewing head and the table top!

9.04 冷却风扇（安装于底护罩）
Cleaning the cooling fan installed on the under cover

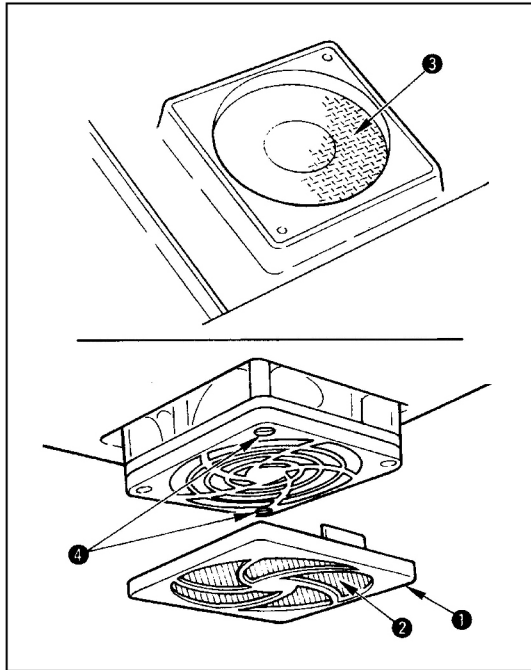

在油盘下部设置的冷却风扇过滤器，如果堆积了布屑等，就会影响机头的冷却效果。如果积存了布屑等时，请卸下风扇护罩①，把过滤器③上的布屑时，请卸下过滤器固定螺丝④，除掉过滤器③上的布屑等。



注意 请待过滤器②、③彻底干燥之后再安装。

Be sure to install filters ② and ③ after they have been completely dried up.

Cloth waster of the like gathers around the cooling fan filter section installed on the lower part of the under cover, and there is a case where cooling effect of the machine head is decreased.

9.05 旋梭部的清扫
Cleaning the hook section

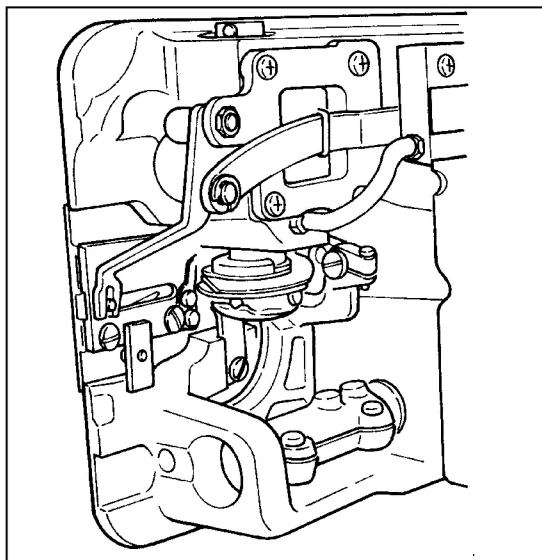

旋梭部积存了布屑、线头之后，缝纫机会发生故障（缝制不良、烧旋梭等），因此请定期进行清扫。

When cloth waste or the like gathers around or adheres to the hook section, trouble(defective sewing, seizure of hook, etc). of sewing machine will be caused. Periodically clean the section.

9.06 旋梭轴油芯的更换方法

Replacing procedure of the hook shaft oil wick

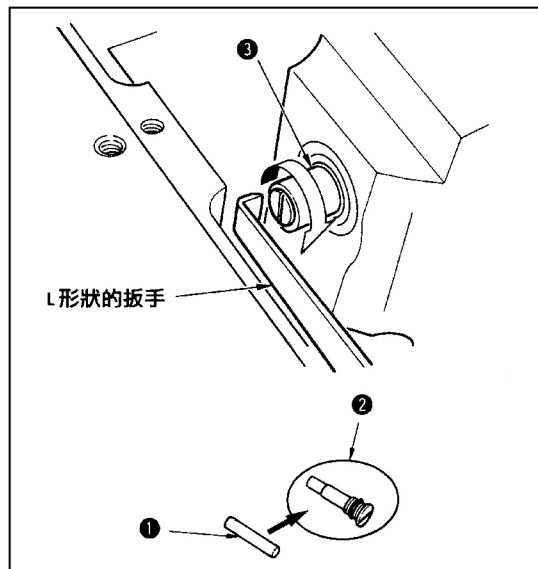

- 1) 旋梭轴油芯①被安装在旋梭轴③的前端。请卸下机针附近的零件（压脚、机针、针板、送料器、旋梭、半圆板），把前端呈L形状的扳手插到旋梭轴油芯螺丝②的槽里，用手正向转动，把螺丝取出来。
- 2) 从取出来的旋梭轴油芯螺丝②里拿出来旋梭轴油芯①，然后把新的旋梭轴油芯①放进旋梭轴油芯螺丝②里。此时，请确认旋梭轴油芯①应正确地插到旋梭轴油芯螺丝②的里面。
*重新组装时，请确认旋梭轴油芯螺丝②的前端孔是否没有损伤。
- 3) 请把旋梭轴油芯螺丝②紧紧的拧进旋梭轴③的前端。

- 1) Hook shaft oil wick ① is mounted on the top end of hook shaft ③ . Remove the needle and the parts around the needle (presser foot , needle , throat plate , feed plate , hook and woodruff plate) , put a spanner , top end of which is L-shaped to the groove section of hook shaft oil wick screw ② , turn the hand wheel in the normal direction of rotation by hand , and draw out the screw .
- 2) Draw out hook shaft oil wick ① from hook shaft oil wick screw ② which has been drawn out and push a new hook shaft oil wick ① to hook shaft oil wick screw ② . At this time , be sure to check that hook shaft oil wick ① has entered up to the end of hook shaft oil wick screw ② .
★ When re-assembling , check that the hole at the top end of hook shaft oil wick screw ② is not broken .
- 3) Securely tighten hook shaft oil wick screw ② to the top end of hook shaft ③ .

9.07 关于专用润滑脂的涂抹

Applying the exclusive grease

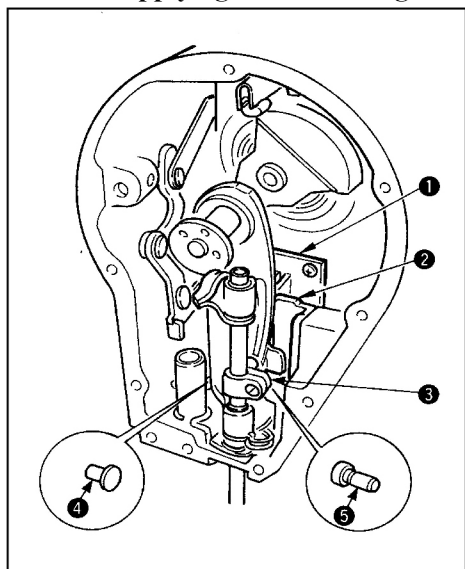

定期地加附属品的专用润滑脂会产生效果。（一般情况下，不需要补加润滑脂，但是在特别严酷的条件下使用）机头面部内的摆动机构零件（①~⑤）请全部涂抹附属的专用润滑脂。但是，针杆请不要涂抹润滑脂。

It is effective to periodically replenish the grease using the exclusive grease supplied as accessories. (It is not necessary to replenish the grease when the sewing machine is operated under the normal condition . However , when the sewing machine is operated under the sever condition , perform replenishing .)

Apply the exclusive grease supplied as accessories to all of the rocking mechanism components (① through ⑤) located inside the face plate section . However , do not apply the grease to the needle bar .